

OfficeServ 7100
System Description



COPYRIGHT

This manual is proprietary to SAMSUNG Electronics Co., Ltd. and is protected by copyright. No information contained herein may be copied, translated, transcribed or duplicated for any commercial purposes or disclosed to the third party in any form without the prior written consent of SAMSUNG Electronics Co., Ltd.

TRADEMARKS

Enterprise IP Solutions

OfficeServ™ is the trademark of SAMSUNG Electronics Co., Ltd.

In addition, product names mentioned in this document may be trademarks and/or registered trademarks of their respective companies.

This manual should be read and used as a guideline for properly installing and operating the product.

This manual may be changed for the system improvement, standardization and other technical reasons without prior notice.

If you need updated manuals or have any questions concerning the contents of the manuals, contact our **Document Center** at the following address or Web site:

Address: Document Center 18th Floor IT Center. Dong-Suwon P.O. Box 105, 416, Maetan-3dong Yeongtong-gu, Suwon-si, Gyeonggi-do, Korea 442-600

Homepage: <http://www.samsungdocs.com>

INTRODUCTION

Purpose

This document introduces product overview, H/W configuration, Specification and functions of OfficeServ 7100, which are required to understand the OfficeServ 7100 system.

Document Content and Organization

This document consists of four Chapters and Abbreviations.

CHAPTER 1. Overview of OfficeServ 7100

Describes the features and the main functions of OfficeServ 7100 over all and introduces system configuration and interface programming.

CHAPTER 2. H/W of OfficeServ 7100

Introduces H/W features, Cabinet composition, boards by functions and configuration of OfficeServ 7100. In addition, this chapter describes various stations, wireless equipment and additional equipment available for OfficeServ 7100.

CHAPTER 3. Specification of OfficeServ 7100

Introduces the detailed standards, such as system capacity, electrical standards, power standards, ring and tone, equipment specification, of OfficeServ 7100.

CHAPTER 4. Functions of OfficeServ 7100

Describes Call, VoIP, Data, Voice Mail(VM), and Web and System management functions provided by OfficeServ.

ABBREVIATION

Describes the acronyms used in this manual.

Conventions

The following types of paragraphs contain special information that must be carefully read and thoroughly understood. Such information may or may not be enclosed in a rectangular box, separating it from the main text, but is always preceded by an icon and/or a bold title.



NOTE

NOTE

Indicates additional information as a reference.

Revision History

EDITION	DATE OF ISSUE	REMARKS
00	07. 2006	First Edition

TABLE OF CONTENTS

INTRODUCTION	I
Purpose	I
Document Content and Organization	I
Conventions.....	II
Revision History.....	II
CHAPTER 1. Overview of OfficeServ 7100	1-8
1.1 Introduction to System.....	1-8
1.1.1 Main Functions	1-8
1.1.2 System Architecture	1-8
1.2 Interface.....	1-8
1.2.1 Interfaces between Sub-modules	1-8
1.2.2 Interfaces between VoIP Components.....	1-8
1.3 Programming	1-8
CHAPTER 2. H/W of OfficeServ 7100	2-8
2.1 Features of H/W	2-8
2.2 Cabinet Configuration	2-8
2.2.1 Configuration of Slots	2-8
2.3 Boards by Functions	2-8
2.3.1 Control Board (MP10, MP11).....	2-8
2.3.2 Voice Trunk Line Board.....	2-8
2.3.3 Voice Station Board	2-8
2.3.4 Voice Trunk Line/Station Board (UNI)	2-8
2.3.5 Data Board (4SWM)	2-8
2.3.6 Voice Application Board	2-8
2.4 Station Phones.....	2-8
2.4.1 Regular Phones	2-8
2.4.2 Digital Phones.....	2-8
2.4.3 IP Phone	2-8
2.4.4 AOM	2-8

2.4.5	Door Phone Interface Module.....	2-8
2.5	Wireless LAN Device.....	2-8
2.5.1	Wireless LAN Base Station (Basic)	2-8
2.5.2	Mobile Station.....	2-8
2.6	Additional Devices	2-8
2.6.1	On Hold/Background Sound Source	2-8
2.6.2	External Broadcasting Units	2-8
2.6.3	Loud Bell	2-8
2.6.4	Common Bell.....	2-8
2.6.5	WEB Management	2-8
2.6.6	SMDR.....	2-8
2.6.7	CTI	2-8

CHAPTER 3. Specification of OfficeServ 7100 **3-8**

3.1	System Capacity.....	3-8
3.1.1	Trunk Line Capacity.....	3-8
3.1.2	Station (Subscriber) Line Capacity	3-8
3.1.3	Number of Channels	3-8
3.2	Electrical Specification	3-8
3.2.1	Signal Specification	3-8
3.2.2	Transmission Characteristics	3-8
3.2.3	Line Conditions.....	3-8
3.3	Power Specification	3-8
3.3.1	OfficeServ 7100 System Power.....	3-8
3.4	Rings and Tones.....	3-8
3.4.1	Ring Cycles	3-8
3.4.2	Tones.....	3-8
3.5	Available Terminals	3-8

CHAPTER 4. Functions of OfficeServ 7100 **4-8**

4.1	Call Functions.....	4-8
4.1.1	Dynamic IP Address Allocation.....	4-8
4.1.2	VM Function	4-8
4.1.3	Router ALG Interworking	4-8
4.2	VoIP Function.....	4-8
4.2.1	VoIP Network.....	4-8
4.2.2	VoIP Trunk Line Interface	4-8
4.2.3	SIP Server Interworking.....	4-8

4.3	Data Functions	4-8
4.3.1	Switches	4-8
4.3.2	Router Functions	4-8
4.3.3	Security.....	4-8
4.3.4	Data Applications Functions.....	4-8
4.4	Voice Mail Function	4-8
4.4.1	Auto Attendant	4-8
4.4.2	General Functions Related to Voice Mail.....	4-8
4.4.3	Additional Voice Mail Functions	4-8
4.4.4	E-mail Gate Way Function	4-8
4.4.5	VM Management	4-8
4.5	Web/System Management.....	4-8
4.5.1	Web Management	4-8
4.5.2	System Management Function	4-8

ABBREVIATION**VIII**

A ~ D	VIII
E ~ K	VIII
L ~ Q	VIII
R ~ V	VIII
W	VIII

LIST OF FIGURES

Figure 1.1	Configuration of OfficeServ 7100 Service	1-8
Figure 2.1	Configuration of OfficeServ 7100 Cabinet	2-8
Figure 2.2	Front View of MP10	2-8
Figure 2.3	Front View of MP11	2-8
Figure 2.4	Front View of TEPR1a	2-8
Figure 2.5	Front View of TEPR12	2-8
Figure 2.6	Front View of 8TRK	2-8
Figure 2.7	Front View of 8SLI	2-8
Figure 2.8	Front View of 8DLI	2-8
Figure 2.9	Front View of 8COMBO	2-8
Figure 2.10	Front View of 16SLI2	2-8
Figure 2.11	Front View of 16DLI2	2-8
Figure 2.12	Front View of UNI Board	2-8
Figure 2.13	Option board of the UNI Board (Voice Trunk Line)	2-8
Figure 2.14	Option Boards of the UNI Board (Voice Station)	2-8
Figure 2.15	4SWM	2-8
Figure 2.16	Front View of MGI64	2-8
Figure 2.17	Regular Phone	2-8
Figure 2.18	DS-5014D	2-8
Figure 2.19	DS-5021D	2-8
Figure 2.20	DS-5038D	2-8
Figure 2.21	DS-5064B	2-8
Figure 2.22	DPIM	2-8
Figure 2.23	WBS24	2-8
Figure 2.24	WIP-5000M	2-8
Figure 3.1	Trunk Line Loop Start Signaling	3-8

LIST OF TABLES

Table 1.1	Interface between Sub-Modules	1-8
Table 2.1	Configuration in the Back side of of OfficeServ 7100.....	2-8
Table 2.2	Boards that can be mounted on the slots.....	2-8
Table 2.3	Boards by Functions	2-8
Table 2.4	Specification of MP10 (MP11) Board	2-8
Table 2.5	Ports of MP10 (MP11) Board	2-8
Table 2.6	Ports and LEDs of TEPRIa Board.....	2-8
Table 2.7	Ports and LEDs of TEPRI2 Board.....	2-8
Table 2.8	Ports and LEDs of 8TRK Board	2-8
Table 2.9	Ports and LEDs of the 8SLI	2-8
Table 2.10	Ports and LEDs of 8DLI Board.....	2-8
Table 2.11	Ports of 16SLI2 Board	2-8
Table 2.12	Ports of 16DLI2 Board	2-8
Table 2.13	Ports and LEDs of the UNI Board	2-8
Table 2.14	Ports and LED of MGI Board	2-8
Table 2.15	AOM Type.....	2-8
Table 3.1	OfficeServ 7100 System Capacity	3-8
Table 3.2	Trunk Line Capacity	3-8
Table 3.3	Station Line Capacity	3-8
Table 3.4	Channels by Slots	3-8
Table 3.5	Electrical Characteristics of the T1 Trunk Line	3-8
Table 3.6	Electrical Characteristics of the E1 Trunk Line.....	3-8
Table 3.7	Electrical Characteristics of the PRI Trunk Line	3-8
Table 3.8	Electrical Characteristics of the DLI Line	3-8
Table 3.9	Electrical Characteristics of the LAN Interface (10 Base-T).....	3-8
Table 3.10	Electrical Characteristics of the LAN Interface (100 Base-Tx).....	3-8
Table 3.11	I/O Voltage of PSU	3-8
Table 3.12	System Ring Cycles.....	3-8
Table 3.13	Cycles of the System Tones.....	3-8
Table 3.14	OfficeServ 7100 Compatible Terminals.....	3-8



This page is intentionally left blank.

CHAPTER 1. Overview of OfficeServ 7100

This chapter describes the features and the main functions of OfficeServ 7100 overall and introduces System Structure, Interface and Programming.

1.1 Introduction to System

OfficeServ 7100 is the most proper communication product for offices with 10 to 25 lines and provides the complex function including voice, data and internet functions. OfficeServ 7100, also, provides the data exchange function using data network as well as the voice call function. Users can enjoy various phone functions and applications at the various platforms such as digital phones, IP phones, mobile phones, PCs and servers.

1.1.1 Main Functions

Main functions and features of OfficeServ 7100 are as follows:

Integrated Communication Environment

OfficeServ 7100 provides the data transmission service by using Local Area Network(LAN), Wide Area Network(WAN) modules as well as the voice call function. Users can conveniently communicate by using wireless/wired integration platforms(Telephones, PCs, Wireless Phones and peripherals) function.

Next-generation Platform

OfficeServ 7100 provides a genuine IP solution integrating mail server, Session Initiation Protocol(SIP) server, Voice Mail(VM) functions via IP-based feature server.

The IP-based feature server is a Linux platform that can continuously add the successive feature server module.

High Quality IP Phone Function

OfficeServ 7100 separates the priority of data packets and voice packets from grouping so that it guarantees the following Quality of Service(QoS) in voice call:

- Layer 2 QoS: Priority Processing(802.1p), VLAN(802.1q)
- Layer 3 QoS: Class Based Queuing(CBQ), Real-time Transmission Protocol(RTP) Priority Queuing, On-Demand Bandwidth management for WAN.

WAN and LAN Functions

OfficeServ 7100 supports WAN and is equipped LAN interface modules so that it can exchange data with external Internet and internal Intranet via 10/100 BASE-T interface without additional data equipment.

Wireless LAN Service

OfficeServ 7100 provides the wireless LAN solution for wireless/wired complex service in office zone. OfficeServ 7100 uses wireless LAN base station so that OfficeServ 7100 can serve wireless/wired voice/data communication and internet access function.

Also, an efficient and convenient working environment can be made at any time or place because sophisticated mobile stations are used for the 7100.

Text-To Speech (TTS) Response

OfficeServ 7100 converts text messages such as e-mails to voice messages and allows the users to listen to the messages through phones.

Mail Server and InstantMessaging

OfficeServ 7100 integrates voice messages and e-mails to function as a mail server, which converts the integrated messages depending on the users' needs and resends them, and sends/receives instant messages.

A Variety of Application Solutions

OfficeServ 7100 offers a variety of application solutions such as OfficeServ News, OfficeServ EasySet, Internet Call Center, R-NMS, Server type On-board Voice Mail Solutions, Integrated Fax Server, and Digital Integrated Recording Systems.



NOTE

Integrated and Application Solution

- 'Integrated' means that OfficeServ 7100 system inter-works with an external solution server and the system and the server operates as one integrated function.
- For detailed information about how to use each application solution, refer to the User's Guide for each application.

1.1.2 System Architecture

OfficeServ 7100 is configured of the main device with a basic cabinet and OfficeServ solution.

The Main device cabinet is a one stage shelf composed of three slots and consists of a control part on the main slot and two subscriber parts on the universal slot. The OfficeServ solution is established in an additional server and uses the solution that is the same as that of OfficeServ7200 and 7400. However, the limited modification concerned with the system structure is allowed.

The service configuration diagram of the OfficeServ 7100 system is shown in the figure below:

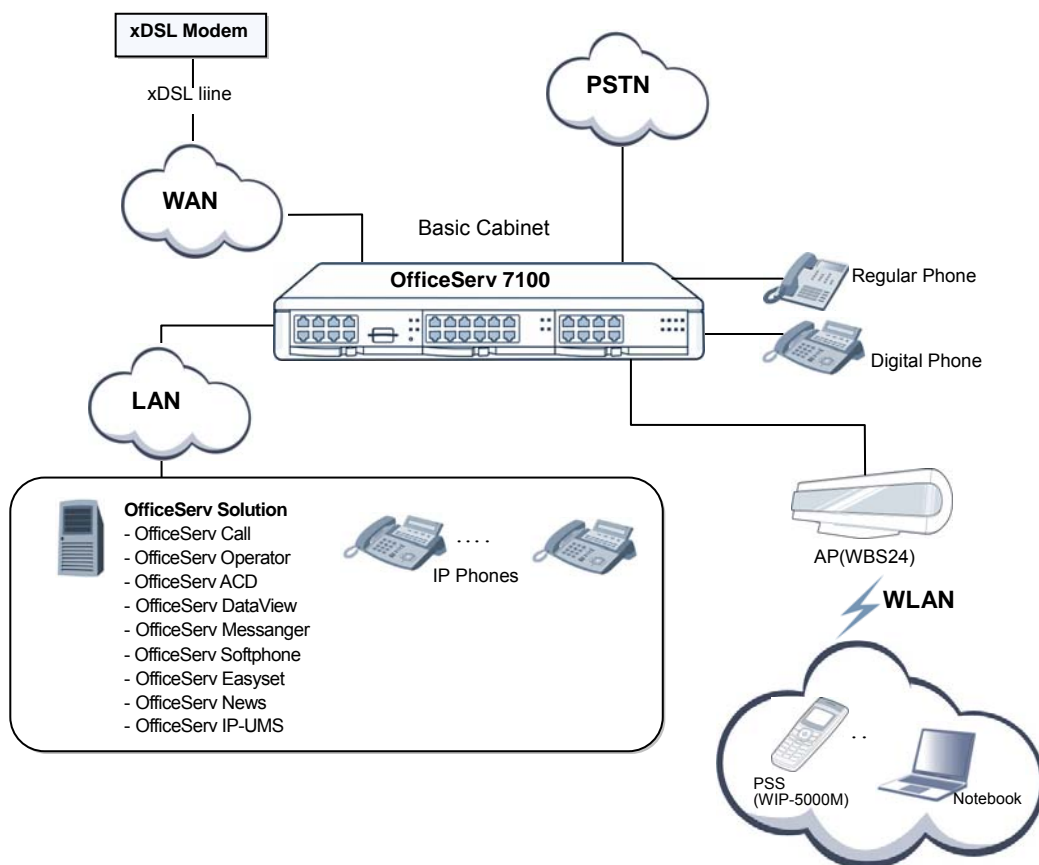

Figure 1.1 Configuration of OfficeServ 7100 Service

Voice Trunk Line Part

The voice trunk line part is configured with digital trunk lines and analog trunk lines. T1E1PRI(TEPRI)/TEPRI2 functions as E1, T1 and Primary Rate Interface(PRI) digital trunk line on a board, sends/receives voices through the trunk line and transmits the data information of 64 kbps per channel. The 8Trunk(8TRK) provides the Caller ID(CID) function within a board in default. If the 4TRM option board is mounted on the UNI board, it operates as a voice trunk board and supports an analog trunk line.

Voice Station Part

The voice station part is configured with Digital Line Interface(DLI), which is a digital station, and Subscriber Line Interface(SLI), which is an analog station, and provides voice services. Multiple station boards can be mounted depending on the combination of port numbers and stations. The digital station has the 16DLI and 8DLI boards, and the analog station has the 16SLI and 8SLI boards. In addition, the 8-combo hybrid board, which is the combination of analog and digital stations, exists. The UNI board equipped with 4SLM and 4DLM operates as an voice station board.

Data Transmission Part

The data module is configured with 4SWM, which is a LAN interface board. 4SWM is an option board that supports data transmission/reception on internet and can be mounted on the d-board slot of M10(11). 4SWM provides 10/100 BASE-T interface and performs the Layer 2 switch function of 4 ports.

Voice Application Part

The voice application module consists of the Voice over Internet Protocol(VoIP) that transmits voice to the data network and the Wireless Local Area Network(WLAN) that transmits voice wirelessly. Media Gateway Interface 64channel(MGI16)/Media Gateway Interface 64channel(MGI64) board converts voice into data and provides the VoIP function.

Application Solutions

OfficeServ 7100 can establish a common server of Linux platform outside its cabinet and provide the following application software. OfficeServ Solution and OfficeServ Admin are constructed in additional servers.

- Mail server
- SIP server
- VoIP-Unified Messaging Service(UMS)
- OfficeServ Solution(CTI, OfficeServ Operator)
- OfficeServ Admin(Web Management, PCMMC, OfficeServ EasySet and System Manager)

1.2 Interface

This section describes the interfaces between the sub-modules of OfficeServ 7100 and the ones between the VoIP elements.

1.2.1 Interfaces between Sub-modules

Table 1.1 Interface between Sub-Modules

Categories	Types	Interfaces
4SWM Interface	Physical Access	IEEE 802.3 10 BASE-TX, IEEE 802.3u 100 BASE-TX
	Connector Type	RJ-45
PSTN Interface	Physical Access	T1, E1, Foreign Exchange Office(FXO)
	Connector Type	RJ-45
	Access Protocol	T1, E1, Loop Start
ISDN Interface	Physical Access	ISDN PRI
	Connector Type	RJ-45
	Access Protocol	ISDN PRI
xDSL/Cable Modem Interface	Physical Access	IEEE 802.3u 100 BASE-TX Ethernet
	Connector Type	RJ-45
	Access Protocol	PPPoE and DHCP
Voice Terminal Interface	Analog Phone	Foreign Exchange Station(FXS)
	Digital Phone	SAMSUNG's Digital Phone
	Wireless LAN AP (Access Point)	802.11b, WBS24(SAMSUNG's Wireless LAN AP)
	Access Protocol	User Agent(UA) to UA

1.2.2 Interfaces between VoIP Components

OfficeServ 7100 provides various VoIP interfaces as follows:

- VoIP Networking
- H.323 VoIP Gateway
- SIP VoIP Gateway
- SIP Server
- System SIP User Agent(UA)
- IP Telephone
- Standard SIP Telephone

In view of signal processing, the interface interworking standards between VoIP components are as follows:

- Proprietary TCP Inter Protocol Communication(IPC)
- SIP UA-to-UA
- UA-to-Server

1.3 Programming

The Man Machine Communication(MMC) program can change the data value used for the system operation program. The MMC program is categorized into three levels, which are technician, operator, and subscriber. Depending on these levels, some MMCs can be programmed by the subscribers while some MMCs cannot.

A password is required for technician level programming or operator level programming; however, a password is not required for subscriber level programming.

Technician-Level Programming

All programs are programmable.

Programming can be made in any stations in the OfficeServ system, but the programming can be made only in a station at the same time.

Operator Level Program

The operator can program only the program specified in ‘Specification of Program 802 Operator Program Range’ by a technician.

Programming can be made in any stations in the tenant group, but the programming can be only made in a station at the same time.

Subscriber Level Program

Only subscriber programs are programmable.



This page is intentionally left blank.

CHAPTER 2. H/W of OfficeServ 7100

This chapter introduces the hardware features, cabinet configuration, and board functions and configuration of the OfficeServ 7100 system. In addition, this chapter describes terminals, wireless LAN equipment, and additional equipment available in the OfficeServ 7100 system.

2.1 Features of H/W

The H/W of OfficeServ 7100 has the following features:

Safety

The materials and parts used for the OfficeServ 7100 hardware are robust and satisfy the mechanical and electric features required for communication systems.

- The cabinet of the OfficeServ 7100 complies with the industrial standards and is assembled by robust and stable metal welding.
- The OfficeServ 7100 hardware does not generate poisonous or corrosive gas, which might be harmful for human bodies or affect the system operation.
- The OfficeServ 7100 hardware is made of materials considering the feature of Electro-Magnetic Interference(EMI).
- The OfficeServ SME hardware has a failure-tolerance to protect the system from the damage caused by over-voltage.

Modularity

The OfficeServ 7100 hardware has functional modules.

- Capacity can be expanded or functions can be changed in each module without interrupting the services for the existing subscribers.
- Each module can be easily installed or removed in the plug-in way.

Maintenance

The OfficeServ 7100 hardware is designed to be maintained with ease and safety.

- The specification of 19-inch rack is observed. The rack is designed to maintain sufficient strength.
- The installers or maintainers can connect cable easily because the ports to be connected to outside are placed on the front panel.
- The front of each module has a LED that indicates failures or operation status so that the operator can easily identify system failures.
- The back of the rack has a ground hole to which a wrist strap for preventing static electricity can be connected.
- The OfficeServ 7100 hardware is designed to protect electronic devices from damages caused by external environment while installing or recovering.

Fire Resistance and Heat Processing

The OfficeServ 7100 hardware is made of fire-resistant materials and parts to protect the hardware from fire.

The OfficeServ 7100 hardware is designed not to affect system performance due to heat generated from inside of the system.

- A specific heat-generated part of the hardware is blocked in order not to affect temperature-sensitive components.
- a 60 mm fans for cooling are installed to exhale internal air to outside.
- The parts installed into the modules are located on the basis of heat distribution.

2.2 Cabinet Configuration

OfficeServ 7100 is configured of the main device with a basic cabinet and OfficeServ solution.

The Main device cabinet is a one stage shelf composed of three slots and consists of a control part on the main slot and two subscriber parts on the universal slot.

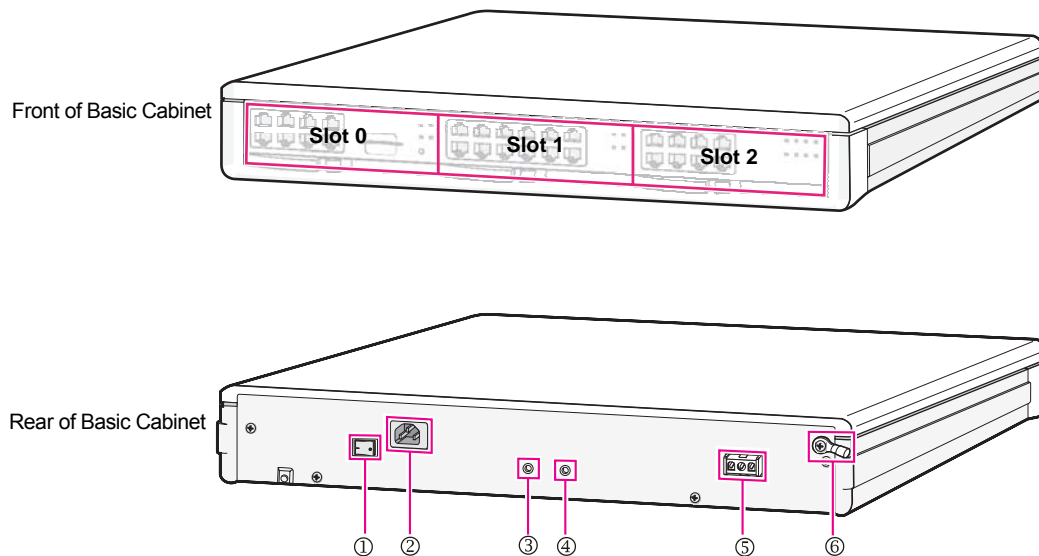

Figure 2.1 Configuration of OfficeServ 7100 Cabinet

Table 2.1 Configuration in the Back side of of OfficeServ 7100

Configuration	Function
① Power Switch	Power on/off the OfficeServ 7100 system.
② Power I/O connector	Connector to connect the power cable
③ AC LED	The LED turns on while applying AC power.
④ DC LED	The LED turns on while the DC power normally comes out.
⑤ Battery Socket	Socket to connect an external battery
⑥ Ground Lug	Lug to ground the system communication

2.2.1 Configuration of Slots

OfficeServ 7100 has three board slots. These boards are equipped with the following boards depending on the configuration of OfficeServ:

Table 2.2 Boards that can be mounted on the slots

Cabinets	Slots	Mountable Boards
control Part	Slot 0	MP10, MP11
Subscriber Part(UNI)	Slot 1 and Slot 2	- OS 7100 Card : UNI board - OS 7200 Card : 8DLI/16DLI, 8SLI/16SLI2, 88COMBO, 8TRK, TEPRIa, LIM, MGI16 - OS7400 Card : TEPRI2, MGI64



NOTE

Blank Board Function

Blank board is a dummy board that functions as a screen to prevent the system from foreign materials when the Universal Slot is not equipped boards.

If an empty board is generated, use a blank board to vent internal air naturally.

2.3 Boards by Functions

OfficeServ7100 has three slots to mount board. Each slot can mount the boards that can perform the following function depending on the configuration type of OfficeServ 7100.

Table 2.3 Boards by Functions

Functions	Boards
Main Control Part	MP10 MP11
Voice Trunk Line	TEPRI, TEPRI2 and 8TRK
Voice Station	8DLI, 16DLI2, 8SLI, 16SLI2 and 8COMPO
Data	4SWM
Voice Trunk Line/Station	UNI(4TRM, 4SLM, 4DLM)
Voice Application	MGI16, MGI64
Power and Fan	PSU and Fan

2.3.1 Control Board (MP10, MP11)

This paragraph describes the configuration and the functions of MP10 and MP11, which are the main control board that controls all functions of the OfficeServ 7100.

MP10(MP11) is a main control part board that controls all functions of OfficeServ 7100 and is mounted on slot 0 of the basic cabinet. It performs the voice switch function, signal processing function and PSS management function. MP10(MP11) carries out the system booting function and data management function.

If 4SWM, which is an option board, is not equipped, MP10(11) is connected to LAN Interface Module(LIM) of the universal slot or an external switch via the LAN interface and starts various applications. If the 4SWM is mounted, LAN interface is connected automatically. MP10(MP11) strengthens the flexibility of the system and by applying the VoIP function and IPC between cabinets raises the reliability by using the HDLC protocol.

Main Functions

The MP10(MP11) board offers the following functions:

- Various application operations via LAN interface
- Convenient installation via MMC card
- Database backup
- Port for Universal Asynchronous Receiver and Transmitter(UART) test
- External/Internal Music On Hold(MOH) and Loud/common bell functions
- Time setting and display function
- Phase Locked Loop(DPLL) function for the synchronization with digital subscribers

Option Board

The MP10(MP11) board can mount a MODEM Board, a 4DLM board or a 4SWM board. in option.

The MODEM board has the following functions:

- The MP10(MP11) board has a 2-Wire Full Duplex modem and can commonly use it with OfficeServ 500 system. Be careful of the direction of the Modem board when mounting/demounting the board to the MP10(MP11) board.
- The Modem board operates in OfficeServ 7100 via V.24 interface and uses a modem chip for Central Office, which can perform Pulse Code Modulation(PCM) highway interface. In addition, the Modem board supports V.90 protocol. OfficeServ 7100 controls the Modem board via serial communication using standard AT commands.

Specification

The specification of MP40 sub-control board is as follows:

Table 2.4 Specification of MP10 (MP11) Board

Categories	Names	Standards
CPU	Processor	M82511G(MP10), M82810(MP11)
	System Clock	375 MHz
	Package	484 BGA
SDRAM (Memory for programs and data)	Capacity	128 MB(for MP10), 256 MB(for MP11)
	Width of Data Bus	32 Bit
SRAM (Memory for Data, Backup)	Capacity	2 MB(1 MB * 2 EA)
	Width of Data Bus	16 bit
Flash ROM (For Booting)	Capacity	512 MB
	Width of Data Bus	8 bit
Time Switch	Device	STC9604
	Basic Switch	256 x 256 Channel
	Data Bus Width	8 Bit
RTC	Device	RTC72423
	Time for Backup	48 Hours
Smartmedia (Memory for programs and data)	Capacity	64 MB
	Width of Data Bus	1 Bit
NAND Flash ROM (Data memory)	Device	1 KB
	Capacity	SPI
EEPROM Data memory (example: MAC Address)	Capacity	STC9604
	Interface	8 Bit
Engine	Device	64 MB
	Width of Data Bus	1 Bit

Front View

The front view of the MP10(MP11) main control part is as shown in the figure below.

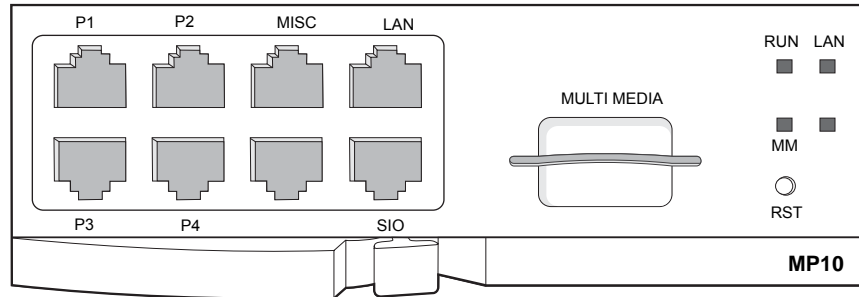

Figure 2.2 Front View of MP10

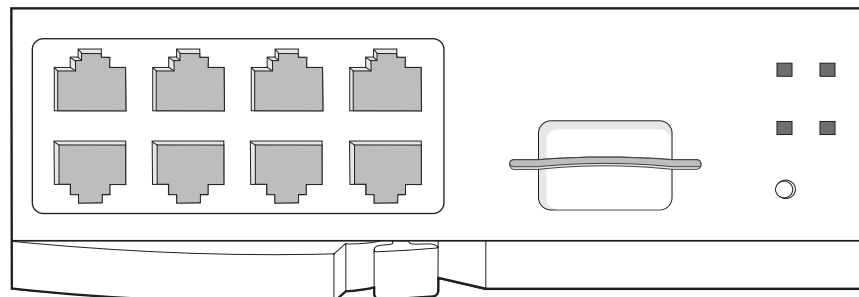

Figure 2.3 Front View of MP11

The components on the front panel of the MP10(MP11) board have the functions below:

Table 2.5 Ports of MP10 (MP11) Board

Ports and LEDs	Functions
P1~P4	Subscriber connection port of 4DLM/4SWM
MISC	Port to connect Ext PAGING, DRY CONTACT and Ext MOH
LAN	Port to connect 10/100 BASE-T LAN
WAN	Port to connect 10/100 BASE-T WAN(only MP11)
SIO	Port connect to serial I/O
Multi Media	Port to insert an MMC card, which is a storage media
RUN LED	Status of Main CPU operation - Off: No-power - On(Green): On Booting, Reset - Blink(Green): Normal Operation of Program The blink cycle is 500 ms while running S/W
LAN LED	Status of LAN operation - Off: Link and no-connection of LAN port - On(Green): Link and LAN port connection - Blink(Green): Tx/Rx

Table 2.5 Ports of MP10 (MP11) Board (Continued)

Ports and LEDs	Functions
WAN LED	Status of WAN operation - Off: Link and no-connection of WAN port - On(Green): Link and WAN port connection - Blink(Green): Tx/Rx
MMC LED	Status of MMC card operation - Off : Non-mounted MMC card - On(Green) : Mounted MMC card - Blink(Green) : In Tx/Rx of MMC card

2.3.2 Voice Trunk Line Board

This section describes the boards that offer the voice service of trunk lines.

2.3.2.1 TEPR1a

The T1E1PRIa(TEPR1a) board provides the digital trunk line. A TEPR1 board provides E1, T1 and ISDN PRI, and functions as the Q-SIG. This board transmits voice via the trunk line and a channel transmits the voice data of 64 Kbps.

Main Functions

The TEPR1a voice trunk line board performs the functions below:

- Selection function for T1/E1/PRI signal process through programming
- Function of a resistance circuit that satisfies both of the T1(100Ω) and E1(120Ω)
- Surge protection over the standard of International Telecommunication Union(ITU)
- Output port protection for line monitors
- Jitter function that satisfies ITU-T I.431 and G.703
- Providing selectable line Codecs(HDB3, AMI)
- Local/remote loop function
- Function for the HDLC or Common Associated Signaling(CAS) through the Common Channel Signaling(CCS)

Specifications

The specifications of the TEPR1a voice trunk line board are as follows:

- E1: 30 channels
- T1: 24 channels
- PRI: 30 channels

Front View

The front view of the TEPRIa voice trunk line board is shown in the figure below:

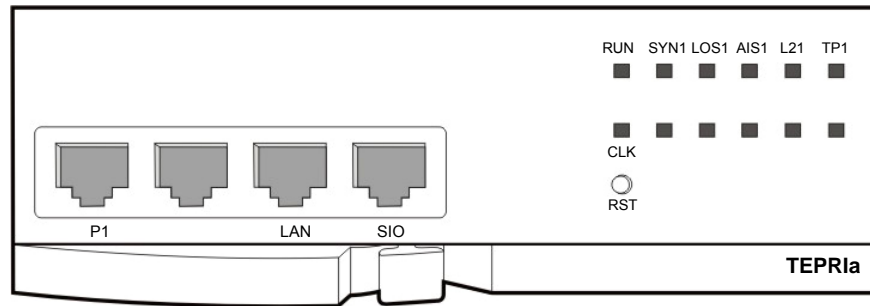

Figure 2.4 Front View of TEPRIa

The components on the front panel of the TEPRIa have the functions below:

Table 2.6 Ports and LEDs of TEPRIa Board

Port, LED	Function Description
P1	Ports to connect T1/E1/PRI cables
LAN	Port connected to Ethernet
SIO	UART port(for test)
TP1	Program type on operating in port1 - On: Port1 operation in PRI - Off: Port1 operation in T1/E1
L21	Layer 2 operation status - On: Normal operation of Layer 2 - Off: Abnormal operation of Layer 2
AIS1	Reception status of alarm bit from the counterparty switch - On: Reception of alarm bit from the counterparty switch - Off: No-reception of alarm bit from the counterparty switch
LOS1	Signal loss status(LOS) from the counterparty switch - On: Weak signal or signal loss from the counterparty switch - Off: Normal signal reception for the counterparty switch
SYN1	Frame synchronization status with the counterparty switch - On: Out of synchronization with the counterparty switch - Off: Synchronization with the counterparty switch
RUN	On(Green): Normal operation in E1(blink at the interval of 200 ms) On(Orange): Normal operation in T1(blink at the interval of 200 ms)
CLK	On when the Reference clock is used as the system clock

2.3.2.2 TEPRI2

TEPRI2 provides the digital trunk line. A TEPRI2 board provides two ports for E1, T1, ISDN and PRI respectively, and functions as the Q-SIG. This board transmits voice via the trunk line and a channel transmits the voice data of 64 Kbps.

Main Functions

The TEPRI2 voice trunk line board performs the functions below:

- Selection function for T1/E1/PRI signal process through programming
- Internal resistance function to enable to satisfy the T1(100Ω) and E1(120Ω) impedances
- Surge protection over the standard of International Telecommunication Union(ITU)
- Output port protection for line monitors
- Jitter function that satisfies ITU-T I.431 and G.703
- Providing selectable line codecs(HDB3, AMI)
- Local/remote loop function
- Function for the HDLC or Common Associated Signaling(CAS) through the Common Channel Signaling(CCS)

Specifications

The specifications of the TEPRI2 voice trunk line board are as follows:

- Two trunk line ports
- E1: 30 channels(per channel)
- T1: 24 channels(per channel)
- PRI: 30 channels(per channel)

Front View

The front view of the TEPRI2 voice board is shown in the figure below:

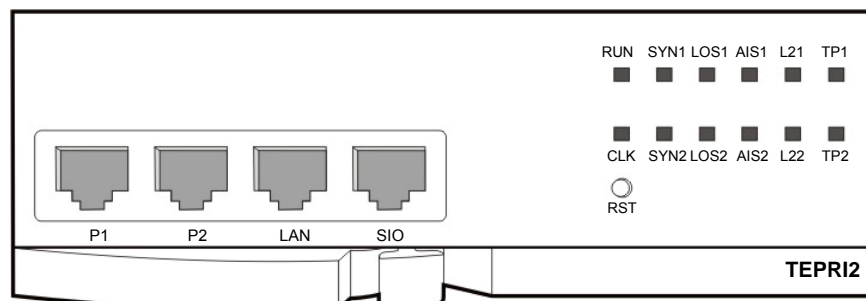

Figure 2.5 Front View of TEPRI2

The components on the front panel of the TEPRI2 have the functions below:

Table 2.7 Ports and LEDs of TEPRI2 Board

Port, LED	Function Description
P1	Port 1 for connecting T1/E1/PRI cables
P2	Port 2 for connecting T1/E1/PRI cables
LAN	Port for connecting to Ethernet
SIO	UART port(for tests)
TP1	Indicating the type of the program operated in Port 1 - On: Port 1 operation in PRI - Off: Port 1 operation in T1/E1
TP2	Indicating the type of the program operated in Port 2 - On: Port 2 operation in PRI - Off: Port 2 operation in T1/E1
L21	Indicating the status of Layer 2 operation - On: Normal
L22	- Off: Abnormal
AIS1	Indicating the reception of the alarm bit of the counterparty switch - On: Alarm bit received
AIS2	- Off : Alarm bit not received
LOS1	Indicating the signal loss(LOS) of the counterparty switch - On: When signals are weak or has been damaged
LOS2	- Off: When signals received properly
SYN1	Indicating the status of frame synchronization with the counterparty switch - On: No frame synchronized
SYN2	- Off: Frame synchronized
RUN	On(Green): Normal operation in E1(Blink in the cycle of 200 ms) On(Orange): Normal operation in T1(Blink in the cycle of 200 ms)
CLK	On when the reference clock is used as the system clock.

2.3.2.3 8TRK

The 8TRK board provides analog trunk line ports. One board has the CID path. In addition, the board provides voice through trunk lines and transmits the voice data of 64 kbps to each channel.

Main Functions

The 8TRK voice trunk line board performs the functions below:

- Detecting ring reception
- Detecting on/off-hook
- Transmitting dial pulse

- CID function
- Line monitoring function that checks if the line is connected periodically to transmit the voice data can be transmitted.
- Caller information relay path function

Specifications

The 8TRK voice trunk line board has eight trunk line ports.

Front View of 8TRK

The front view of the 8TRK board is shown in the figure below:

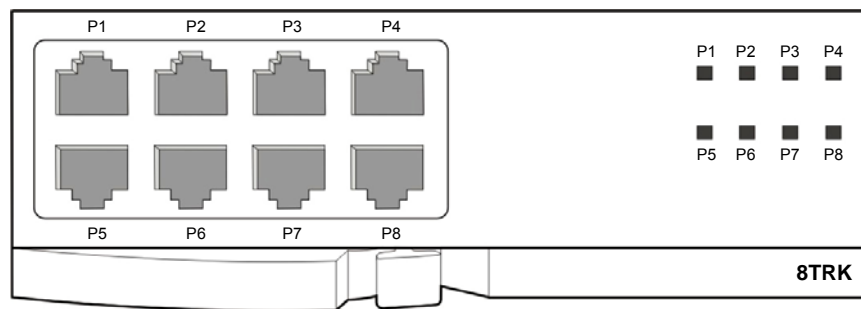

Figure 2.6 Front View of 8TRK

The components on the front panel of the 8TRK have the functions below:

Table 2.8 Ports and LEDs of 8TRK Board

Port, LED	Function Description
P1~P8	Trunk Ports
P1~P8 LED	The status of ports - Off: Not used - On: In use - Blink: On receiving a ring

2.3.3 Voice Station Board

This section describes the board that offers the station voice service.

2.3.3.1 8SLI

The 8SLI(Single Line Interface) board supports 8-port for analog stations. It interworks with regular phones via the station to provide voice communication.

Main Functions

The main functions of the 8SLI voice station board are as follows:

- Generating the ring of 20 Hz
- Detecting Dial Tone Multi Frequency(DTMF)/dial pulse
- Detecting on/off-hook
- Generating a tone

Specifications

The specifications of the 8SLI/16SLI voice station board are as follows:

- 8SLI Board: Eight station ports

8SLI Front View

The front view of the 8SLI board is shown in the figure below:

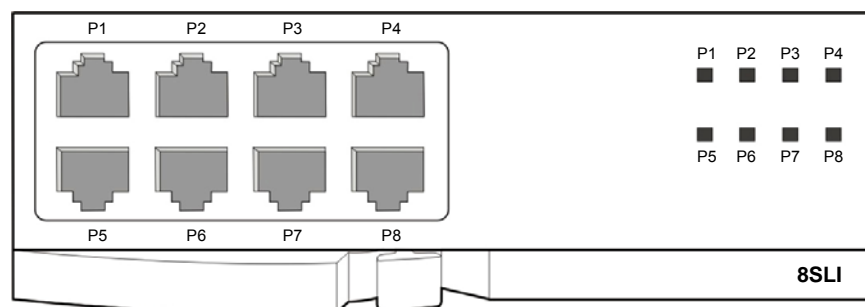

Figure 2.7 Front View of 8SLI

The components on the front panel of the 8SLI have the functions below:

Table 2.9 Ports and LEDs of the 8SLI

Port, LED	Function Description
P1~P8	Station ports of regular phones
P1~P8 LED	The status of Ports - Off: Not used - On: Station in use

2.3.3.2 8DLI

The 8DLI(Digital Line Interface) board supports 8-port for digital stations. It interworks with Samsung digital phones via the station to provide voice communication.

Specifications

The specifications of the 8DLI voice station boards are as follows:

- 8DLI Board: Eight station ports and 2B+D(Two voice channel and one signal channel) provided

Front View of 8DLI

The front view of the 8DLI voice station board is shown in the figure below:

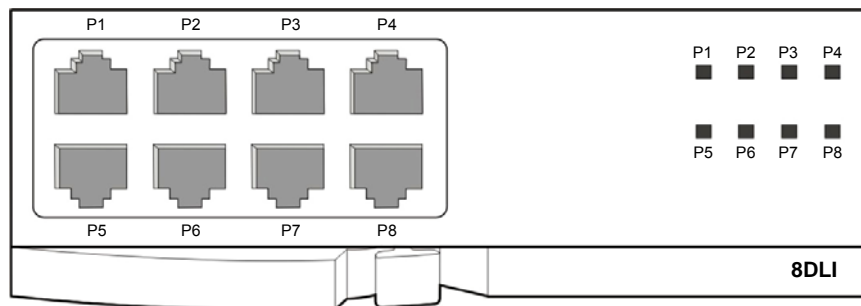

Figure 2.8 Front View of 8DLI

The components on the front panel of the 8DLI have the functions below:

Table 2.10 Ports and LEDs of 8DLI Board

Port, LED	Function Description
P1~P8	Station ports of Samsung digital phones
P1~P8 LED	The status of the ports - Off: Not used - On: Station in use

2.3.3.3 8COMBO

The 8COMBO board supports eight ports of analog stations and eight ports of digital stations simultaneously. It interworks with regular phones or digital phones to provide voice communication.

Main Functions

The main functions of the 8COMBO voice station board are as follows:

- Generating the ring of 20 Hz
- Detecting DTMF/dial pulse
- Detecting on/off-hook
- Generating a tone

Specifications

The specifications of the 8COMBO voice station board are as follows:

- Eight analog station ports
- Eight digital station ports

Front View of 8COMBO

The front view of the 8COMBO voice station board is shown in the figure below:

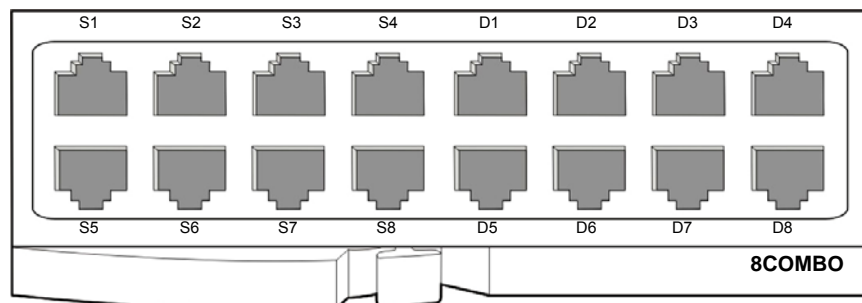

Figure 2.9 Front View of 8COMBO

2.3.3.4 16SLI2/16MWSLI

The 16SLI2 board has 16-ports for analog stations. It interworks with regular phones via the station to provide voice communication. 16MWSLI is a board that a message waiting function is added to the functions of 16SLI2.

Main Functions

The main functions of the 16SLI2 board are as follows:

- Generating the ring of 20 Hz
- Detecting Dial Tone Multi Frequency(DTMF)/dial pulse
- Detecting on/off-hook
- Generating a tone
- Power Fail Transfer(PFT)
- Message Waiting(16MWSLI)
- Transmitting Polarity Reverse Signal(PRS)

Specifications

The specifications of the 16SLI2/16MWSLI boards provides 16 station ports.

Front View of 16SLI2/16MWSLI

The front view of the 16SLI2/16MWSLI boards is shown as follows:

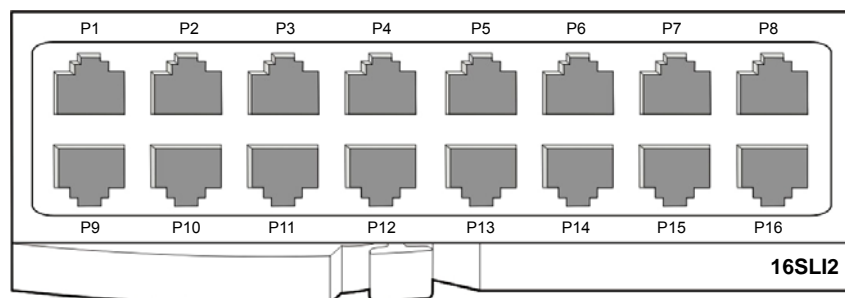

Figure 2.10 Front View of 16SLI2

The components on the front panels of the 16SLI2/16MWSLI boards have the functions below:

Table 2.11 Ports of 16SLI2 Board

Port, LED	Function Description
P1~P16	Station Ports of Regular Phones

2.3.3.5 16DLI2

The 16DLI2 board has 16-ports for digital stations. It interworks with Samsung digital phones via the station line to provide voice communication.

Specifications

The specifications of the 16DLI2 voice station board as follows:

- 16 station ports provided
- 1B + D(One voice channel and one signal channel) provided

Front View of 16DLI2

The front view of the 16DLI2 board is shown in the figure below:

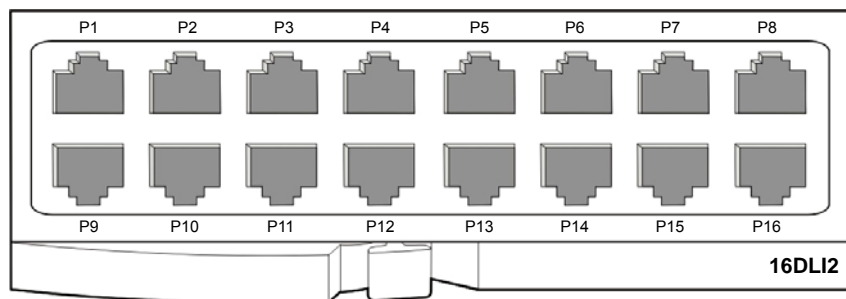

Figure 2.11 Front View of 16DLI2

The components on the front panel of the 16DLI2 have the functions below:

Table 2.12 Ports of 16DLI2 Board

Port, LED	Function Description
P1~P16	Station Ports of Samsung digital phones

2.3.4 Voice Trunk Line/Station Board (UNI)

The UNI board can be used as a voice trunk line board or voice station board depending on the mounted option board. If a 4TRM option board is mounted in the UNI board, it operates as a voice trunk line board. If 4SLM and 4DLM option boards are mounted, it operates as a voice station board.

Main Functions

The main functions of the UNI board are as follows:

- 3-pair of connector to mount an option module
- Option Module control logic
- -54 V power Control function

Specifications

- Use of a 4TRM option board: four trunk ports
- Use of a 4SLM option board: Four station ports
- Use of a 4DLM option board: Four station ports

Front View

The front view of the UNI board is shown in the figure below:

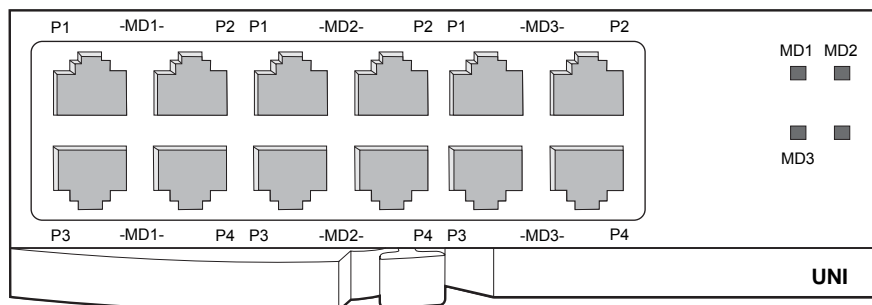

Figure 2.12 Front View of UNI Board

The components on the front panel of the UNI board functions as follows:

Table 2.13 Ports and LEDs of the UNI Board

Port, LED	Function Description
MD1 P1~P4 MD2 P1~P4 MD3 P1~P4	Port support in accordance with the option boards mounted on the position of MD1, MD2 and MD3
MD1 LED	Module mounting status at the MD1 position and subscriber status - Off : No-module mounted - On(Green) : Module mounted & Module port in Idle mode - Blink(Green) : Module port in Busy mode

Table 2.13 Ports and LEDs of the UNI Board (Continued)

Port, LED	Function Description
MD2 LED	Module mounting status at the MD2 position and subscriber status - Off : No-module mounted - On(Green) : Module mounted & Module port in Idle mode - Blink(Green) : Module port in Busy mode

The UNI board mountable option boards are as follows. If a 4TRM option board is mounted on the UNI board, the UNI board operates as a voice trunk line board.

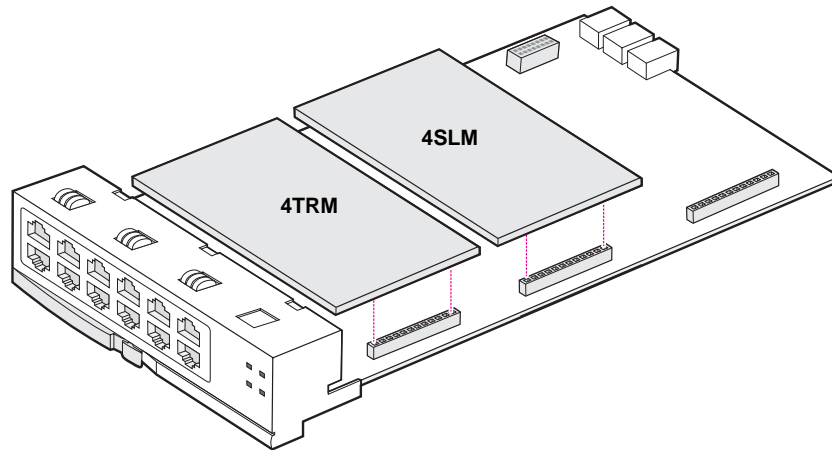

Figure 2.13 Option board of the UNI Board (Voice Trunk Line)

If 4SLM and 4DLM option boards are mounted on the UNI board, the UNI board operates as a voice station board.

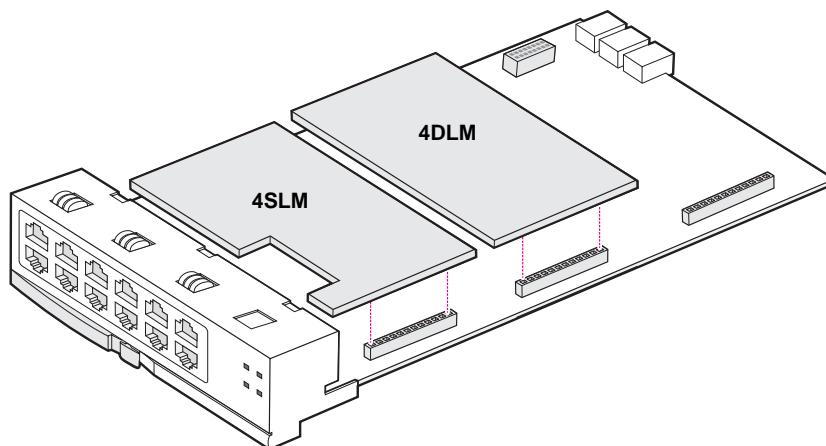

Figure 2.14 Option Boards of the UNI Board (Voice Station)

2.3.5 Data Board (4SWM)

This section describes the data board that receives/transmits data from/to Internet or Internet. 4SWM, which is a data board of OfficeServ 7100, provides 10/100 BASE-T interface and performs the Layer2 Switch function as the data transmission/reception board to/from Internet.

Main function

The main functions of the SWM board are as follows:

- Auto-detection function of 10/100 BASE-T and Full/Half duplex
- 802.1p and VLAN function to support QoS
- Layer 2 Switch function

Specifications

LIM-P data board, 4SWM, provides four 10/100 BASE-T ports.

Front View

The front view of the LIM-P data board, 4SWM, is shown in the figure below:

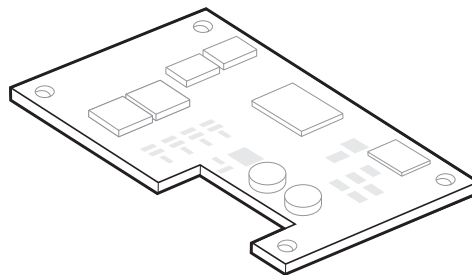

Figure 2.15 4SWM

2.3.6 Voice Application Board

This section describes the interface board that uses Digital Adaptor for Subscriber Loop(DASL) to send/receive voice to/from the phone system and wireless base station as well as the board that converts voice to data, and then sends/receives the data.

2.3.6.1 MGI16/MGI64

The MIG16/MGI64 boards enables to convert voice to data, and then send/receive the data via the data network. The MGI16 and the MGI64 boards provide up to 16-channel and 64-channel, respectively. In addition, the boards provide voice compression/decompression functions of G.729, G.723 and G.711, and support the VoIP function to enable to execute a client and a server in a board.

Main Functions

The main functions of the MGI16/MGI64 voice application boards are as follows:

- Voice compression/decompression: G.729, G.723, G.726, G.711
- Facsimile relay: MGI16 and MGI64 provide 2-channel and 8-channel, respectively.
- Echo cancellation
- Volume adjustment
- Silence suppression

Front View

The front view of the MGI64 voice application board is shown in the figure below:

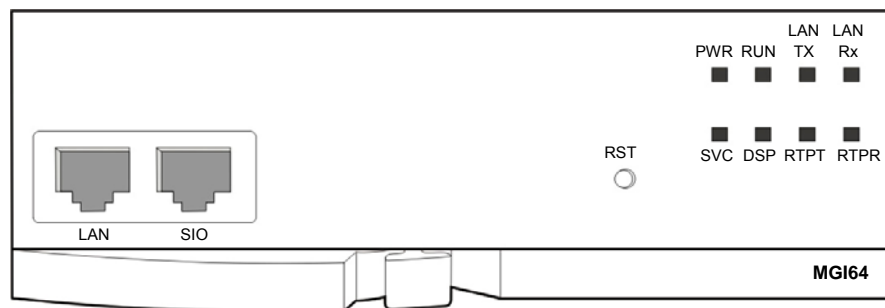

Figure 2.16 Front View of MGI64

The components on the front panels of MGI16 and MGI64 are as follows:

Table 2.14 Ports and LED of MGI Board

Port, LED	Function Description
LAN	Ports for connecting Ethernet
SIO	UART port(for tests)
RST	Button for resetting MGI board
PWR LED	Power supply status - Off: Power supply blocked - On: Power supplied
RUN LED	MGI operation - Off: Power supply blocked - On: On booting - Blink: RAM program in operation
LAN TX LED	Ethernet data transmission status - Off: No data - On or Blink: On data transmission
LAN Rx LED	Ethernet data reception status - Off: No data or no link connected - On or blink: On data reception

Table 2.14 Ports and LED of MGI Board (Continued)

Port, LED	Function Description
SVC LED	Service - LED blinks when the task service of the software is available
DSP LED	VoIP DSP operation - LED blinks when VoIP DSP is operated
RTPT LED	Voice packet transmission - LED turns on when transmitting voice packets
RTPR LED	Voice packet reception - LED turns on when receiving voice packets

2.4 Station Phones

This section describes the types and features of analogue/digital station phones that can be connected to the OfficeServ 7100 system.

2.4.1 Regular Phones

The regular phones used for voice calls are connected to the ports of the 8SLI/16SLI/8COMBO boards mounted on the Universal slot of the OfficeServ 7100 system.

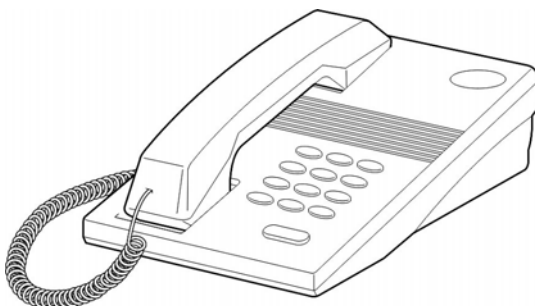

Figure 2.17 Regular Phone

2.4.2 Digital Phones

Digital phones are used for the transmission of voice calls and data, and are connected to the ports of the 8DLI/16DLI/8COMBO board mounted on the Universal slot of the OfficeServ 7100 system.

If 2B is supported, the digital phones may be used by connecting with devices such as Add On Module(AOM), Keypset Daughter Board(KDB)-D, and KDB-S.

2.4.2.1 DS-5000 Series

DS-5038D/5021D/5014D

The DS-5038D/5021D/5014D phones are two-line LCD digital phones and have 38, 21, or 14 program buttons that allow the subscribers to register their desired functions and make calls by using a handset/speaker phone.

The DS-5021D/5014D phones have the navigation buttons that allow the users to easily use the phone functions(searching phone numbers by recent calling number, recent called number and name, setting call forwarding and an alarm, and searching speed dials) and connect with the KDB-D/S/F devices. For detailed information on the phones, refer to 'User's Guide for OfficeServ Digital Phones, DS-5038D/5021D/5014D'.



Figure 2.18 DS-5014D



Figure 2.19 DS-5021D



Figure 2.20 DS-5038D

2.4.3 IP Phone

The IP phones are a new concept of Internet phones that use an IP address to send/receive voice or data. The IP phones use the installed data network lines to make voice communications and do not need telephone lines. The IP phones can be connected with the devices such as a switching hub and are connected with other digital phones through the MP10/MP11 or MGI16/MGI64 board of the OfficeServ 7100.

2.4.4 AOM

The Add On Module (AOM) is the extended module type digital terminal where the program buttons and LEDs in a digital phone are expanded. Desired functions can be specified into the buttons on the AOM. For information on the figure of each AOM or how to connect the AOM, refer to the User's Guide about the AOM.

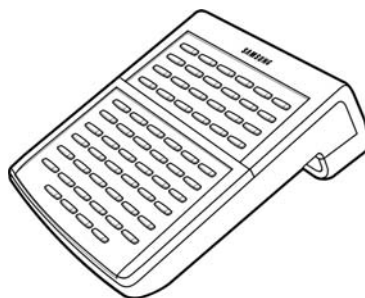

Figure 2.21 DS-5064B

The AOMs available in the OfficeServ 7100 system and phones that can be connected with the AOM are as follows:

Table 2.15 AOM Type

AOM Type	Connectable Phone
DS-5064B AOM	DS-5000 series digital phone
DS-4014 AOM	DS-4000 series digital phone
DS-4064 AOM	
DS-24SE AOM	DS-24SE digital phone
DS-2024E AOM	DS-2000 series digital phone
DS-3020S AOM	DS-3000 series digital phone

2.4.5 Door Phone Interface Module

The Door Phone Interface Module(DPIM) is the module that connects door phones and door open/close devices to the OfficeServ 7100. The line port of the door phone interface device is connected to the DLI port of the OfficeServ 7100 system. The door box port of the door phone interface device is connected to the line port of the door phone.



Figure 2.22 DPIM



NOTE

Reference

For information on how to connect terminals such as a door phone interface device, refer to 'OfficeServ 7100 Installation Guide.'

2.5 Wireless LAN Device

This section describes the wireless LAN BTS and mobile stations that can be connected with the OfficeServ 7100 system.

2.5.1 Wireless LAN Base Station (Basic)

Wireless LAN base station(WBS24) of 2.4 GHz consists of wire and wireless processing blocks. The wire processing block has IEEE 802.3 Ethernet interface connected with the LAN. The wireless processing block has the wireless LAN RF interface in the wireless frequency band of 2.4 GHz under the IEEE 802.11b standard.

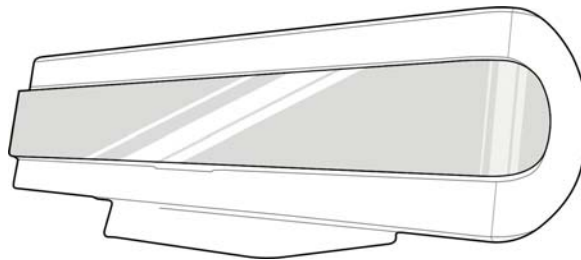

Figure 2.23 WBS24

The wire Ethernet interface is connected to the LAN based on 10/100 BASE-T and transmits/receives data(e.g., Internet access) other than voices. The wireless processing block transmits/receives voice data for wireless voice calls and accesses the wireless Internet. The maximum transmission speed on the wireless section is 3 to 4 Mbps. Various people can simultaneously access the wireless Internet using a WBS24.

2.5.2 Mobile Station

Mobile station WIP-5000M(wireless IP-Phone mobile type), which is a local wireless mobile station, uses the wireless LAN of IEEE802.11b to allow the users to make voice calls. The WIP-5000M performs the wireless IP phone function that exchanges as packets that meets the wireless LAN standard by compressing voice(Voice over WLAN). The WIP-5000M supports hand-over when moving between the APs(WBS24s) and can use data terminals such as laptops that enable wireless LAN in the same place. The WIP-5000M performs the message service functions supported by the OfficeServ 7100 system as well.



Figure 2.24 WIP-5000M

2.6 Additional Devices

This section describes the types and features of devices that can be connected optionally when the OfficeServ 7100 is installed.

2.6.1 On Hold/Background Sound Source

The OfficeServ 7100 is connected with cassettes or radios in addition to the basic tone provided by the system or internal sound source to allow subscribers to listen to melodies other than ones specified to the subscribers. The devices such as the cassettes or radios are called on hold/background sound source.

The on hold/background sound source is mainly used for on hold tone, background music, or announcement and can be used by being connected with the external sound source devices below:

- FM radio
- CD player
- Cassette tape recorder



NOTE

Output Resistance

The speaker output resistance of FM radios, CD players, or cassette recorders are normally 8Ω or 16Ω .

2.6.2 External Broadcasting Units

The OfficeServ 7100 is connected with external broadcasting units such as amplifiers or speakers for consumers instead of internal speakers. These external broadcasting units are embedded in the control board, and are connected via the MISC1 ports.

2.6.3 Loud Bell

The Loud Bell allows the users to listen to ring signals from outside, and amplifiers or external speakers are used for the Loud Bell.

The Loud Bell is connected via the MISC1 port of the MIS board, which is an optional board that can be mounted on the control board. Once the secondary call device is connected, a call signal rings from only a specific phone set to MMC 205 Assign Pair Station of Loud Bell.

2.6.4 Common Bell

The Common Bell is a ring that can be specified when a station group is set. Once a station in a group rings, other stations in the group ring. The Common Bell is connected via the MISC1 port of the MIS board, which is an optional board that can be mounted on the control board.

2.6.5 WEB Management

The Web management is the software for the installation/maintenance of the OfficeServ 7100. The functions for controlling the system database are implemented in the form of menus in the Web management; thus, the WEB management is convenient to use when the system data are displayed or changed. In addition, the users can understand and use the system operational commands easily because the commands for maintenance are integrated.

2.6.6 SMDR

The Station Message Detail Recording(SMDR) manages entire calling data such as calls between station subscribers connected with the OfficeServ 7100 as well as local/long distance/international calls. The OfficeServ 7100 provides calling data. Connect the SMDR printer or SMDR computer with the OfficeServ 7100 to use the SMDR data provided by the OfficeServ 7100 system.

- The SMDR printer can display call history received from the OfficeServ 7100, however does not display data other than the call history(i.e., toll data).
- The SMDR computer displays call history received from the OfficeServ 7100 and calculates toll using the SMDR software based on the call history. Accordingly, the SMDR computer allows the users to use data more efficiently than the SMDR printer.

2.6.7 CTI

The Computer Telephony Integration(CTI) is the integrated system of computer and telephony. That is, the CTI interworks computers with PBXs so that the computers make use of the PBXs as computer resources and the PBXs share the computer resources. The CTI provides the operator with convenience and reduced costs and the customers with enhanced services and reduced call processing time.

Particularly, the CTI call center system configures data on the customers into databases. Based on the databases, the call center can consult with the customers one to one. The CTI integrates communication, computers, and database based on phones as a basic medium to allow the users to perform marketing using computers such as customer-focused telemarketing.

The OfficeServ 7100 supports the standard Telephony Application Programming Interface(TAPI), which is implemented in a client/server environment and controls third party calls.

CHAPTER 3. Specification of OfficeServ 7100

This chapter describes the capacity of the OfficeServ 7100, various signal specification, power specification, rings and tones, compatible boards and terminals, and equipment specifications.

3.1 System Capacity

Up to 1344 lines can be installed and operated in the OfficeServ 7100 system, and the line ratio of the station and trunk line can be adjusted within the capacity depending on the users' needs. Table 3.1 below shows the maximum line capacity of the OfficeServ 7100:

Table 3.1 OfficeServ 7100 System Capacity

System Configuration	Maximum Line Capacity
Cabinet	<ul style="list-style-type: none"> - Digital Trunk Line Channel: 60 - Analog Trunk Line Channel: 24 - station Port: 24 - VMS Port: 4 - VoIP Channel: 72(8(MP10/11) + 64(MGI64)) - H.323 Trunk Channel: 32 - SIP Trunk Channel: 32 - SPnet Trunk Channel : 64 - Samsung IP Phone Channel: 64 - WIP Phone Channel: 64 - SIP Phone Channel: 43 - ISDN Terminal Channel: 32 - Voice Mail Channel: 4 - DTMF Generation Channel: 8 - CID Generation/Reception Channel: Each 4-channel - Conference Function: 5-person 6-group - 4SWM internal power: 4 - DTMF Reception: 8 ea

3.1.1 Trunk Line Capacity

The maximum trunk line capacity of the OfficeServ 7100 based on its configuration is shown in the table below:

Table 3.2 Trunk Line Capacity

System Configuration	Analogue	Digital		
	LOOP TRK	T1 TRK	E1 TRK	PRI TRK
Basic cabinet	24	48	60	T1: 48 E1: 60

3.1.2 Station (Subscriber) Line Capacity

The maximum station line capacity for regular phones and digital phones in the OfficeServ 7100 based on its configuration is shown in the table below:

Table 3.3 Station Line Capacity

System Configuration	Regular Phones	Digital Phones
Basic cabinet	24	24

3.1.3 Number of Channels

The number of channels of each slot of OfficeServ 7100 and the number of CID receivers and DTMF receivers are as follows:

Table 3.4 Channels by Slots

Category	Slot	Number of Channels
Basic cabinet	Slot 2 and 3	64
CID receiver	Embedded MP10/11	4
DTMF receiver	Embedded MP10/11	8

3.2 Electrical Specification

3.2.1 Signal Specification

The signal processing protocol means the methods for connecting signals between the trunk lines, stations and system, and also means the method of providing the status information.

3.2.1.1 Trunk Line Signaling

Loop Start

In processing loop start signals, the on-hook and the off-hook statuses are controlled by the flow of electric current. The loop is a closed loop trunk circuit or a standard 2500-type set loop.

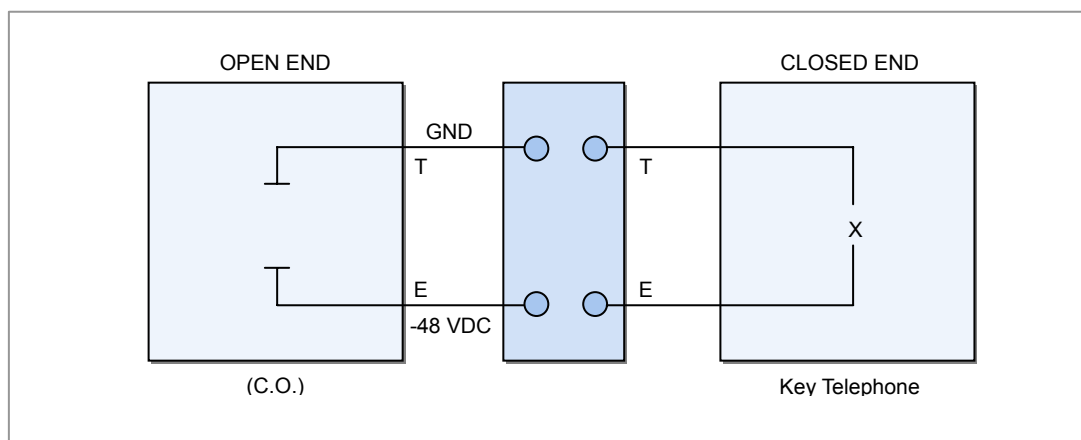

Figure 3.1 Trunk Line Loop Start Signaling

T1 Trunk Line

- The electrical characteristics of the T1 trunk line comply with the ITU G.703 and G.704 standards.

Table 3.5 Electrical Characteristics of the T1 Trunk Line

Categories		Specifications
Transmission speed		1544 kbit/s \pm 50 ppm
Code		AMI or B8ZS
Pulse type		Regular square wave: When indicating all valid signals, comply with the mask(G.703) regardless of the codes.
Transmission media		A pair of twisted lines
Load resistance		100 Ω
Indicated(pulse) nominal peak voltage		3.00 V
Signal Level	Power at the frequency of 772 kHz	\pm 12~ \pm 19 dBm
	Power at the frequency of 1544 kHz	25 dB or higher when the power is less than the power at the frequency of 772 kHz

- The signaling specification and the signaling method of the T1 trunk line should comply with the ITU G.703 and G.704 standards.

E1 Trunk Line

- The electrical characteristics of the E1 trunk line comply with the ITU G.703 and the G.704 standards.

Table 3.6 Electrical Characteristics of the E1 Trunk Line

Categories	Specifications
Transmission speed	2048 kbit/s \pm 50 ppm
Code	High Density Bipolar of Order 3(HDB3)
Pulse type	Regular square wave: When indicating all valid signals, comply with the mask(G.703) regardless of the codes.
Nominal and pulse	244 ns
Jitter of the I/O terminal	Refer to the G.823
Transmission media	A pair of twisted lines
Load resistance	120 Ω
Indicated(pulse) nominal peak voltage	3.00 V
Blank(non-pulse) peak voltage	0 \pm 0.300 V

- The signaling specification and the signaling method of the E1 trunk line comply with the ITU G.703 and G.704 standards E1.

Characteristics of the ISDN Interface Transmission

- The electrical characteristics of the ISDN(PRI) interface comply with the ITU I.431 and ETS 300 011 standards

Table 3.7 Electrical Characteristics of the PRI Trunk Line

Categories	Specifications
Transmission speed	2048 kbits/s \pm 50 ppm
Code	High Density Bipolar of Order 3(HDB3)
Pulse type	Regular square wave: When indicating all valid signals, comply with the mask(I.403) regardless of the codes.
Nominal and pulse	244 ns
Transmission media	A pair of twisted lines
Load resistance	120 Ω
Indicated(pulse) nominal peak voltage	3.00 V
Blank(non-pulse) peak voltage	0 \pm 0.300 V

- The electrical characteristics of the Digital Line Interface(DLI) are shown in the table below:

Table 3.8 Electrical Characteristics of the DLI Line

Categories	Specifications
Transmission speed	384 kbits/s
Code	Alternate Mark Inversion(AMI)
Pulse type	Typical AMI Waveform

3.2.1.2. LAN Signaling

- The electrical characteristics of the 10 Base-T, which comply with the IEEE802.3 standards, are shown in the table below:

Table 3.9 Electrical Characteristics of the LAN Interface (10 Base-T)

Categories	Specifications
Transmission speed	10 Mbps
Transmission code	Manchester coding(When the transmission data is '0', the higher level than the middle of the bit is inversed into the lower level. When the transmission data is '1', the lower level than the middle of the bit is inversed into the higher level)
Access control method	Carrier Sense Multiple Access/Collision Detect(CSMA/CD)
Transmission media	UTP(Unshielded Twisted Pair) CAT3, CAT4, CAT5, STP(Shielded Twisted Pair)
Number of the UTP pairs	2 pairs
Characteristic resistance	100 Ω
Cable thickness	Diameter: 0.51 mm(24 AWG), External diameter: 5 mm

- The electrical characteristics of the 100 Base-Tx, which comply with the IEEE802.3u standards, are shown in the table below:

Table 3.10 Electrical Characteristics of the LAN Interface (100 Base-Tx)

Categories	Specifications
Transmission speed	100 Mbps
Transmission code	4B/5B+MLT-3 - 4-bit/5-bit converts the data of 4bit into the data of 5bit and encodes the data on the physical layer. Multi Level Transmission-3(MLT-3) encodes transmission data into 3 levels(high, middle, and low).
Access control type	CSMA/CD
Transmission media	UTP CAT5, STP

Table 3.10 Electrical Characteristics of the LAN Interface (100 Base-Tx) (Continued)

Categories	Specifications
Number of UTP pairs	2 pairs
Characteristic resistance	100 Ω
Cable thickness	Diameter: 0.51 mm(24 AWG), External diameter: 6 mm



NOTE

Mode Band

The mode band shown in the previous table is a quality indicator of the multimode optical fiber related to the transmission speed. Its unit is generally MHz.Km, and is proportional to the value of the bit rate of the optical signal(the on-off speed) X the maximum transmission distance. The largeness of this value means the high optical signal with high bit rate can be transmitted. Each mode band is standardized also in the use of short wave and long wave laser.



NOTE

Categories of UTP Cable

UTP Cables are classified into Straight-through UTP cable and Crossover UTP cable. The Straight-through UTP cable is used for connecting the LIM module of OfficeServ 7100 system to other modules(MCP, MGI, WIM, 4DSL). The Crossover UTP cable is used for connecting only LIM module to LIM module.

3.2.1.3 Station Signaling**Dial Pulse Signaling**

- Ratio-10 Pulse Per Second(PPS)
- Make/Break Ratio(M/B ratio)-33 %: 66 %(It can be adjusted by the software.)
- The minimum signaling time between digits-20 msec(It can be adjusted by the software.)

DTMF Push Button Dialing

The DTMF signal processing complies with the ITU standard, which enables the user to send/receive the signals of digital phones through the trunk line and to process the signals of regular phones.

3.2.2 Transmission Characteristics

- Attenuation
 - Attenuation between subscribers: Less than 6 dB
 - Attenuation between the subscriber and local trunk line: Less than 0.5 dB
- Characteristic resistance of the line: 600 Ω
- Weighted noise: Less than -65 dBm
- Crosstalk attenuation: Less than -68 dBm
- Frequency band: 300~3400 Hz
- Insulation resistance: More than 1 M Ω

3.2.3 Line Conditions

- Length for installation:
 - Regular phones: Up to 1 km(When the AWG #24 cable is used)
 - Digital phones: Up to 400 m(When the AWG #24 cable is used)
 - Door phones: Up to 400m(When the AWG #24 cable is used)
 - AOMs: Up to 400m(When the AWG #24 cable is used)
 - Length between 4WLI and to Combo AP: Up to 600 m(When the AWG #24 cable is used)
- Leakage resistance between lines: More than 20 K Ω
- Leakage resistance between grounds: More than 20 K Ω

3.3 Power Specification

3.3.1 OfficeServ 7100 System Power

OfficeServ 7100 operates by AC input power or battery power and supplies the system cabinet with the backup power of -54 V, -5 V, +5 V, +3.3 V, +12 V, or -56 V.

Table 3.11 I/O Voltage of PSU

Power Supply Devices		Specifications
Power Supply Board(PSU)	Input power	AC 110V , 220V(option)
	Input power	- DC -54 V, 0.9 A - DC +5 V, 4 A - DC -5 V, 0.3 A - DC +3.3 V, 5 A - DC +12 V, 0.2 A - DC -56 V, 0.3 A(for backup)

3.4 Rings and Tones

3.4.1 Ring Cycles

The OfficeServ 7100 provides the trunk line rings, station rings, door rings, and alarm rings. The ON/OFF cycle of each ring is shown in the table below:

Table 3.12 System Ring Cycles

Rings	ON/OFF Cycles
Trunk line ring	1000/3000 ms
Station ring	400/200/400/3000 ms
Door ring	400/200/400/200/400/2000 ms
Alarm ring	400/200/400/200/400/200/400/1000 ms



NOTE

Ring ON/OFF Cycle

The ON/OFF cycle can be adjusted by changing the values of the system database

3.4.2 Tones

The output voltage and the frequency of the ring signals in the OfficeServ 7100 are as follows:

- Output voltage: 75 V
- Frequency: 20 Hz

The OfficeServ 7100 provides the users with various tones to notify the users of the status of functional operation and give feedback to the users. The ON/OFF cycles of currently specified tones are shown in the table below:

Table 3.13 Cycles of the System Tones

Tones	ON/OFF Cycles
Dial tone	1000/250 ms
Busy Tone	500/500 ms
Do Not Disturb tone	250/250 ms
Ring Back tone	1000/2000 ms
Call Park tone	Continuous
Confirmation/Caution/Barge-In tone	50/50 ms
Call Back/Hold tone	500/3500 ms
Ring Back tone	1000/2000 ms
Error/Number Unobtainable tone	250/250 ms
Message Camp On tone	Continuous

3.5 Available Terminals

The terminals available to the OfficeServ 7100 are shown in the table below:

Table 3.14 OfficeServ 7100 Compatible Terminals

Types	Terminals
DS-5000 series digital phones	DS5038S/5021D/5014D/5007S/5000S/5064B
ITP-5000 series IP phones	ITP-5121D/5114D/5107S
Wireless LAN devices(WLAN)	WIP-5000M(Mobile Station), WBS24(Access Point Device)
iDCS Series	iDCS28D/18D/14D/64D
Others	DPIM, door phone



NOTE

Compatible Terminals

All the compatible terminals of the iDCS 500 Premium system are available to the OfficeServ 7100. Since the compatible terminals can be changed depending on system settings, contact the system administrator.



This page is intentionally left blank.

CHAPTER 4. Functions of OfficeServ 7100

This chapter describes the functions of the OfficeServ 7100 related to calls, VoIP, data, UMS, and web/system management

4.1 Call Functions

The OfficeServ 7100 processes station calls, trunk line calls, application calls, or various signals through the PSTN and VoIP networking.

4.1.1 Dynamic IP Address Allocation

MGI16/MGI64 Configuration

The MGI mounted in the OfficeServ 7100 can be operated by receiving the dynamically allocated IP address from the data server rather than manually setting the IP address.

IP Phone Configuration

The IP phones or Session Initiation Protocol(SIP) phones registered to the OfficeServ 7100 also can be operated by rather receiving the dynamically allocated IP address from the data server than manually setting the IP address.

4.1.2 VM Function

Auto Attendant/Voice Mail

OfficeServ 7100 provides the auto attendant function and the voice mail function by using embedded MGI for the Voice mail service.

4.1.3 Router ALG Interworking

NAT Application Level Gateway (ALG)

When various functions such as the VoIP signal process function and gateway function executed through the IP network in the OfficeServ 7100 are executed in the Network Address Translation(NAT) network, the conversion between the private IP address and public IP address may be required. In this case, the call module and the data module interwork each other, share the information converted between the private IP and public IP and automatically convert addresses for the smooth service. This function is only provided to the OfficeServ 7100 MP11.

VPN ALG

When various functions such as the VoIP signal process function and gateway function executed through the IP network in the OfficeServ 7100 are executed in the Virtual Private Network(VPN), the system should be set to prevent the packet blocking during the IP address conversion due to the tunneling. In this case, the call module and data module interwork each other and share the tunneling conversion information for smooth services. This function is only provided to the OfficeServ 7100 MP11.

4.2 VoIP Function

The VoIP function indicates the smooth signal processing gateway function between the existing phone and SIP standard device based on the standard SIP protocol.

4.2.1 VoIP Network

To communicate with another system through the VoIP networking, the MGI/MGI64I board should be installed in OfficeServ 7100. The VoIP networking function is corresponding to the PRI/Q-SIG networking function.

4.2.2 VoIP Trunk Line Interface

The OfficeServ 7100 provides the VoIP trunk line interface(H.323/SIP). The OfficeServ 7100 controls calls, and individual MGI/MGI64 board connects speech path.

4.2.3 SIP Server Interworking

Telephone Registration

This function enables to register phones connected to Office 7100 to the external SIP server and perform the call processing service with the external standard SIP terminal. OfficeServ supports the registration in two ways: registration of OfficeServ 7100 general directory number and individual registration to register each station connected to OfficeServ.

Basic Call Processing

This function enables to register the phones connected to OfficeServ 7100 to an external SIP server and provides standard SIP terminal and trunk line call service.

Additional Call Processing

OfficeServ 7100 provides the following additional services concerned with the trunk line call service via the phones registered to an external SIP server.

- Hold/Resume
- Consultation Call
- Consultation Transfer
- Blind Transfer
- Call Forward

4.3 Data Functions

The OfficeServ 7100 functions as routers, switches, performs security function, or serves as data network applications or data access interfaces(WAN, LAN, DMZ).

4.3.1 Switches

802.1d Spanning Tree

This function enables to prevent the generation of a Packet Forwarding Loop and perform the call forwarding by using the forwarding tree by the spanning tree algorithm.

802.1p Packet Priority

The switch extracts the priority field from the Ethernet frame configured according to the 802.1p specification standard, and discriminatively processes the frame according to the priority of the specified operation standard.

The packets are categorized into emergent packets and non-emergent packet and are processed.

VLAN (802.1Q)

The Virtual Local Area Network(VLAN) groups the related equipment in the work group units according to the LAN operational policy regardless of the location of the user equipment. The VLAN also processes switching for the work groups. The VLAN removes the effects of unnecessary broadcasting packet and configures the stable switching subnet only for the corresponding group by separating and processing the group in the virtual LAN. Accordingly, the switch can provide the differentiated QoS services and the VLAN can be configured based on the switch port and MAC address.

IGMP Snooping

L2 switch(located in the lower layer of the IP router) without the IGMP(Internet Group Management Protocol) function is located between the IP router and multicast group member(host), intercepts the IGMP message. And then the L2 switch operates in the IP router like the group member and operates in the group member like the IP router, which is referred as the IGMP Snooping.

The IP layer multicast group information included in the IGMP message is reflected in the MAC filtering database, its own switching database. The group information is processed in the MAC multicast address format mapped with the IP multicast address.

802.1x Supported

IEEE 802.1x Standards defines the formats and the operation procedures of EAP over LAN(EAPoL) frame that can send/receive the Extensible Authentication Protocol(EAP) between terminals and Access Point(AP). These standards are called the port security protocol because they can be used in the procedure permitting the network access of the terminal only by acquiring the physical port license of Bridge or wireless AP from the authentication server. This performance of the authentication procedure by ports enables the control of charging policies, usage restriction, or band allocation, etc separately by ports.

PoE (IEEE 802.3af) Function Supported

Power over Ethernet(PoE) is designed so that no additional power supply to the network equipments used in wireless AP or other wired LAN is necessary. PoE allows the user to send the data and the power simultaneously via one Ethernet cable, which reduces the installation cost in most cases as well as provides the high flexibility in selecting the installation site of the wireless AP and the network equipments.

QoS Function Supported

OfficeServ 7100 provides the function of 802.1p Packet Priority and Level Classification Setup for supporting the Quality of Service(QoS). The 802.1p Packet Priority is the expansion of the standard MAC header in the network packet. This expansion provides the packets with priority by using 3-bit. The packet of the higher priority is treated preferentially and is processed ahead than the packet of the lower priority. The Level Classification Setup function gives the packets the levels of High/Low and processes them according to their levels, which makes the differential services possible.

4.3.2 Router Functions

Various Network Interface

The OfficeServ 7100 provides the E0, E1, and E2 network interfaces, which are connected to the WAN through Ethernet interface, provides the serial network interface connected through the V.35, HSSI serial interface.

Static Routing

The OfficeServ 7100 configures the fixed routing table between each network interface to process the static routing. In this case, the routing table cannot be dynamically changed by the routing protocol, and specific routing services will be provided according to the pre-set routing policy.

WAN Interface (Ethernet, PPPoE, DHCP Client)

E0, E1, E2 Ethernet WAN Interface enables the connection to internet by using the Static IP, PPPoE, DHCP client protocol.

Routing Protocol

The OfficeServ 7100 supports the routing information-exchanging protocol to react on the network environmental change and to effectively process the routing.

- Routing Information Protocol version1(RIPv1) and RIPv2
These protocols are widely used for managing the routing information in the mid-small sized independent network such as a group of LANs.
- Open Shortest Path First version2(OSPFv2)
This routing protocol is used prior to the RIP in the large-size independent network. A router detects and reports any change in the routing table or the network to other routers. In this way, all routers share the same routing information.

Multicast Routing

- Internet Group Management Protocol(IGMP)
Internet Group Management Protocol(IGMP) is a protocol that manages the multicast group operating at one Ethernet segment. It controls the segment so that a user can subscribe or secede as a member of the specific multicast group.
- Distance Vector Multicast Routing Protocol(DVMRP)
Distance Vector Multicast Routing Protocol(DVMRP) is a protocol for supporting the transmission of the multicast data in a network. This protocol sends the multicast data in a format of unicast packet, and the packets are reassembled into multicast data at the destination. DVMRP can be operated in various formats of networks including Ethernet, and even can be operated via the routers that the multicast is not supported with.
- Protocol Independent Multicast-Sparse Mode(PIM-SM)
PIM-SM is designed in order to route multicast packets into multicast groups and in order to construct the allocation tree efficiently at WAN, by which is optimized in the environment where the data stream occur in many places.

Routing between VLAN Groups

The communication between the VLAN groups through the routing is possible.

HTBQ/ Bandwidth on Demand (BoD)

The queuing process is differentially performed according to the level table where the routing process priority for a data server is defined.

RTP Priority

The RTP(Real-Time Transport Protocol) packet is a VoIP media packet. The queuing process for the RTP packet is prior to that for other data pack, which helps to maintain the tone quality. This function is useful when using the VoIP function in the network where the VoIP packet that should be processed in real time and other packets for the general office work are mixed processed.

IP-ToS Process

This function checks the ToS(Type of Service) field of the IP header and processes it according to priority of the corresponding routing in the data server. This function reproduces the ToS field flowing into the data server, performs the routing process first of all, and heightens the process priority in the next HOP.

4.3.3 Security

NA T/PT (In/Out/Exclusive/Redirect)

The security function supports the conversion function between the private IP address and public IP address in the network where security is required.

The Inbound, Outbound, Exclusive, and Redirect functions are supported.

- In bound: This function performs the forwarding process for the packet coming from the WAN to the IP and port of the LAN specified in the NAT/PT conversion table.
- Outbound: This function converts the IP address of the transmitter into the global IP address according to the NAT/PT conversion table for transmitting the packet from the LAN to the WAN.
 - Exclusive: This function is used for the IP address that is not applied by the NAT/PT conversion.
 - Redirect: When the Domain Name Server(DNS) server IP in the data server management sector is changed, each IP terminal uses the pre-DNS IP and the this function changes the DNS IP by registering the post-DNS IP into the Redirect table

Firewall

- Access filtering
This function prevents the access to disallowed IP address to control the access for the resource non-disclosed to the outside and to control the external resource for which the membership in the LAN may access.
- DMZ function
This function is used for connecting the web server and mail server, which are firewall-protected LAN networks but need to be freely accessed from the outside, to the subnet separated from the LAN network where the firewall blocking is not applied. In this way, the access from the outside can be more smoothly with the access control service through the firewall.
- Port Forwarding
This function is almost the same as the DMZ function but is used for connecting to specific network without the separately divided DMZ port. This function is used for the Extra network services as well as the DMZ function. The Extra network is configured for the party out of the office to access Intranet in the office through Internet. In this network, the user should take care of security on Intranet.

Intrusion Detection System (IDS)

This function monitors the packets on the network and detects the packets, which can damage the network operation, making the network more stably operate. The IDS is divided into various types from a detection type where a specific-type attack is detected to the abnormal traffic detecting type, which are based on the Snort Rule(www.snort.org) defining the intrusion pattern and types. The detected packets are sorted and processed into Close connection/port or service disable/Alarm/log based on the intrusion pattern and the level and processed. In the case of the alarm, The system will notify to the system administrator immediately.

Virtual Private Network (VPN)

- **VPN function**

The system provides the private network function by using the Internet that is an open network based on the. The OfficeServ 7100 provides the VPN gateway function based on the IPSecurity(IPSec), which is useful to build the enterprise network with reduced cost and enforced security by using the public network such as Internet rather than the dedicated network.
- **VPN Tunnel Mode**

This mode processes the VPN function by configuring the tunnel between the VPN gateway and the gateway in each data module of the OfficeServ 7100. Up to 100 VPN channels are available for one VPN.
- **PPTP**

PPTP is a tunneling protocol for using the IP-based network. PPP encapsulates the data by wrapping the data with PPP header. PPTP is a protocol that reconfigures the packets by adding Generic Routing Encapsulation(GRE) header and IP header to this so that the packets can be transmitted via IP inter network.
- **L2TP**

L2TP is a protocol that combines PPTP and Layer 2 Forwarding(L2F), which collects the strong points of PPTP and L2F. That is, it encapsulates a user PPP frame, which is a Layer 2 frame, in an additional message called L2TP and then transmits it to the device connected to the public network such as IP, X.25, frame relay, or Asynchronous Transmission Mode(ATM).

4.3.4 Data Applications Functions

DHCP

The OfficeServ 7100 can assign the IP address by operating the DHCP. When using the DHCP server in another subnet, the OfficeServ 7100 supports the DHCP relay function. The IP address of the IP equipment connected to the OfficeServ 7100 is can be easily managed.

SIP Aware ALG (SIP Application Gateway)

This function is used for re-creating packets for the smooth communication by checking the SIP signal process packets according to the NAT/PT table in the data server. When using the data server of the OfficeServ 7100, the SIP equipment can operate regardless of the packet blocking caused by the firewall or the MAT/PT conversion.

Outside ALG Interface

This function enables the outside application to retrieve or control the information such as the NAT/PT conversion information, firewall blocking information, and the VPN tunnel information processed in the data server. This function supports the control packets, which are used for H.323, VoIP networking, and IP telephone operating in the Call server, to be smoothly serviced without any blocking.

System Management Interface

This function allows the administrator to report and manage the alarm, event, traffic, and logging information including the IDS information of the data server into the system administrator package through the TCP/UDP. Whether to report can be optionally specified based on the management data type.

Management Function (Web/CLI/SNMP/RMON)

- CLI: This function is used for configuring the data server function by using the CLI(Command Line Interface) on the Telnet.
- Web: The user can configure and view the operation of the data server functional block by using the web browser.
- SNMP : SNMP agent collects and stores the device information according to the specification(MIB) installed and determined at each network devices. The SNMP manager existing at the place separated from the agent manages the overall network by collecting the information on SNMP gent distributed at the network.

4.4 Voice Mail Function

The OfficeServ 7100 provides auto answering, voice message, and e-mail transfer by using built-in MGI without additional device.

4.4.1 Auto Attendant

Announcement Replay and Auto Call Forward

- This system replays the announcement when the calling party is connected to the auto attendant. This announcement can be specified based on holiday, working hour, or non-working hour.
- The auto call forward connects the calling party to the desired subscriber's station when the calling party dials a station number in the auto attendant. In this case, the call routing function will be also provided, which detects whether the entered phone number is valid, or intellectually detects that the length of the phone number can be changed.

Announcement Auto Change Based on the Schedule

This function allows the administrator to automatically changing and replaying the announcement based on holiday, working hour, and non-working hour.

Announcement Change by Telephone

This function allows the administrator to change the announcement by interfacing the auto attendant from the remote site.

Call Forwarding to the Mailbox on the Busy Line

When a party interfaces to the auto attendant and tries to connect a call to a busy station, the called party on the busy station can use this function to forward the call to the voice mailbox.

Waiting Queuing Process on the Busy Line

When a party interfaces to the auto attendant and tries to connect a call to a busy station, the message "Please hold up the phone in the minute since the line is busy" is played and retries to connect a call for a specific time if the "Call Forward to the Mailbox on the Busy Line" function is not set. If the line continues busy after the maximum wait time, a voice message is provided asking the user whether to forward the call to the voice mailbox or disconnect the call.

Direct Connection to the Mailbox

This function allows the user to access the auto attendant and directly connect the call to the mailbox of a specific user by using the prefix rather than try a call to the subscriber's station.

Time Control for the Announcement

This function allows the administrator to control the maximum input time for the announcement when the administrator directly records the announcement for the auto attendant.

Cutting off Announcements when Digits are Entered

If the user enters digits as the target station number when the voice announcement is played in the auto attendant, the system stops the announcement and processes the entered digits.

Announcement Replay

This function allows the administrator to listen to multiple voice announcements on a specific telephone which have already recorded.

4.4.2 General Functions Related to Voice Mail

Subscriber Authentication and Auto Login

- When a subscriber tries to login the mailbox, the subscriber authentication function checks the password to prohibit an invalid party from logging in a mailbox of other party. In this case, the mailbox number and password are entered and checked in the order.
- When any party directly connects a call to the mailbox with the key number of the mailbox on the station phone, the system uses the auto login function to require only the password but the mailbox number since the caller's phone number has been known. The user can enter the mailbox number and connect a call to the mailbox by using the hot key(speed key) on the telephone of other party.

Voice Message Record/Replay/Store/Delete/Re-Send/Reply

- A caller can make a call to the mailbox of the called party and leave a voice message. The caller can send the message at a specific time(Send reservation) or listen to his recorded message and record again.
- A subscriber can login his own mailbox to listen to voice messages as well as the message recording time, calling number, and caller ID. The subscriber can delete, send to another party or group, or reply to the corresponding message while listening to the message.
- The subscriber can delete all messages currently stored in the mailbox.

Voice Message Pause/Play Continue/Next Play/Previous Play/Play Again

The user can pause and replay the current message, play the next or previous messages, or play the current message again while listening to a message.

New Message Auto Replay

The user logged-in the mailbox can optionally set whether to automatically replay new voice messages.

Setting the Maximum Message Numbers for a Mailbox

This function is used for specifying the maximum message number for a mailbox. The number of messages in the mailbox cannot exceed the specified maximum message number. In this case, the corresponding announcement is provided.

Setting the Maximum Time for Storing Messages

The system automatically deletes the voice messages after a specific time if the user does not delete the message after listening to the voice message. In this case, the user can specify the time for auto message deletion.

Setting the Maximum Message Length to be stored at a time

The message length is limited. Therefore, if the user records message for a specific time, the recording is automatically completed and the voice announcement is provided saying “Message recording is completed”.

Announcement Change based on the Schedule

This function automatically changes and provides the announcement based on the holiday, working hour, or non-working hour.

Voice Message Notice

New voice message is notified the user on the LCD screen or by the LED of the user’s telephone.

Private Mailbox Management

The user can record/listen to/delete the name of the private voice mailbox or change the password of the private voice mailbox. The user can also record/listen to/delete the greeting of the private voice mailbox.

4.4.3 Additional Voice Mail Functions

Answering Machine Emulation (AME)

This function is almost the same as that of the auto answering machine. If a called party does not receive the call, the call is forwarded to the AME. In this case, the called party can listen secretly to the forwarded call or reply to the call by using the functional key.

Call Back to the Caller ID/Call Number

This function allows the users to call back to the Caller ID or called number(a telephone number left with a voice message).

Voice Message Notification

The UMS rather directly connects the voice message to the subscriber's station than notifies the message on the LCD screen or the LED of the phone when a new voice message arrives. Therefore, the user optionally can listen to the new message by receiving the phone.

Call Record

This function allows the users to record the contents of the call in the user's voice mailbox during the call. The digital phone has a hot key through which the user can record it by just pressing the hot key. Since the analog phone does not have the hot key, the user should login the web and click the corresponding button to use this function.

Private Voice Memo

This function allows the users to memorize information such as the schedule or telephone number by voice. This function is usually the same as the general voice message function. However, this voice memo can be separately managed as if memos.

Stop the Private Mailbox Function

This function allows the users to stop the private mailbox function. If any party try to access the prohibited mailbox, the message will be displayed notifying that this mailbox cannot be used.

4.4.4 E-mail Gate Way Function

Sending Voice mails by using E-mails

This function enables to convert a newly incoming voice mail into a WAV file format that can be replayed in a PC and attach the voice mail to the user's E-mail.

Notifying the arrival of voice mails by using E-mails

This function enables to notify the arrival of a voice mail by using an E-mail.

4.4.5 VM Management

Database Backup and Recovery

The user can backup or recover the VM database operating in the OfficeServ 7100.

Mailbox Management

The mailbox administrator can add or delete mailboxes. This function can be executed on a telephone. The mailbox administrator can retrieve the mailbox information on the web.

Alarm Information Management

The user can specify the alarm level(including Major, Minor) for alarms generated in the VM and view the alarm information that has occurred for a specific time.

Auto-Installation

If the OfficeServ 7100 system starts, a voice mailbox suitable for the database is automatically created. Therefore, the installation time is reduced.

Password Security

Since all administration functions are only available after entering the password, the fraudulent use by a certain subscriber or user without permission is prevented.

Voice Greeting Programming

The user can record a greeting by using a phone and add or delete voice mailboxes.

4.5 Web/System Management

The OfficeServ 7100 system performs the management for Voice Call, Voice Mail and Router/Switch server configuration and the information search function via the embedded Web service function and supports the functions to monitor and collect the operational status of the functional blocks in the system.

4.5.1 Web Management

Database Backup

The user can back up and restore the system database to a MMC card via Web.

System File Upload

User Account Management

The user can view the current status of (Operational status, alarm information, etc) the OfficeServ 7100 in real time. The user can collectively manage each functional block(call server, data server, or feature server) by operating the PCMMC package or connecting web servers of the corresponding server.

Voice Call Management

The configuration information of the OfficeServ 7100 installed in the site can be displayed. The configuration information is as follows:

Voice Mail Management

This function displays various event information such as the information on critical error or warning generated in the OfficeServ 7100. The user can group events by arranging or searching events.

Router/Switch Management

This function displays the access log for the OfficeServ 7100. The user can group each access log by arranging and searching logs.

4.5.2 System Management Function

configuration Management

The following configuration of OfficeServ 7100 installed in a site can be displayed:

- Configuration of OfficeServ 7100 Units
- Information on OfficeServ 7100 Version
- Information on Data Function Setting/Version
- NAT Information
- Feature Server(SIP, UMS and mail) Function Setting/Version Information

Event Management

Various event information such as fatal error, warning generated in OfficeServ 7100 is displayed. Events can be grouped through the arrangement or search function.

Access Log Management

Management access history about OfficeServ 7100 can be displayed. Access logs can be grouped through the arrangement or search function.

Traffic Management

The traffic information(phone usage, data transmission/reception amount, VoIP call processing, mail transmission/reception) generated for a certain time in OfficeServ. This information is useful as the statistical data for a fixed time.

Call Details Record Management

Call Detail Record(CDR) served by OfficeServ 7100 can be stored and displayed.



ABBREVIATION

A

AC	Alternating Current
ALG	Application Level Gateway
AME	Answering Machine Emulation
AOM	Add On Module
AP	Access Point
AS	Autonomous System
ASIC	Application Specific Integrated Circuit
AWG	American Wire Gauge

B

BRI	Basic Rate Interface
BRM	BRI Module
BoD	Bandwidth on Demand

C

CBQ	Class Based Queuing
CDR	Call Detail Record
CID	Caller Identification
CLI	Command Line Interface
CRC	Cyclic Redundancy Code
CSMA/CD	Carrier Sense Multiple Access/Collision Detect
CTI	Computer Telephony Integration

D

DASL	Digital Adaptor for Subscriber Loop
DPIM	Door Phone Interface Module
DC	Direct Current
DHCP	Dynamic Host Configuration Protocol
DID	Direct Inward Dialing
DLI	Digital Line Interface
DMZ	DeMilitarized Zone

DNS	Domain Name Server
DPIM	Door Phone Interface Module
DSL	Digital Subscriber Line
DSP	Digital Signal Processor
DTMF	Dial Tone Multi Frequency
DVMRP	Distance Vector Multicast Routing Protocol

E

EAP	Extensible Authentication Protocol
EMI	Electro-Magnetic Interference

F

FE	Fast Ethernet
FXS	Foreign Exchange Station
FXO	Foreign Exchange Office

G

GK	GateKeeper
GND	Ground

H

HDB3	High Density Bipolar of order 3
HDLC	High-level Data Link Control
HSSI	High Speed Serial Interface

I

IDS	Intrusion Detection System
IGMP	Internet Group Management Protocol
IMAP4	Internet Message Access Protocol version 4
IP	Internet Protocol
IPC	Inter Processor Communication
ISDN	Integrated Services Digital Network
IPSec	Internet Protocol Security
ITU	International Telecommunication Union

K

KDB	Keypset Daughter Board
-----	------------------------

L

L2TP	Layer 2 Tunneling Protocol
LAN	Local Area Network
LCD	Liquid Crystal Display
LCR	Least Cost Routing
LED	Light Emitting Diode
LIM	LAN Interface Module

M

MP	Main Control Processor
MFM	Multi-Frequency Module
MIS	Miscellaneous
MMC	Man Machine Communication(Code, Command)
MPD	Metering Pulse Detection

N

NAT	Network Address Translation
-----	-----------------------------

O

OSPF	Open Shortest Path First
------	--------------------------

P

PC	Personal Computer
PCM	Pulse Code Modulation
PFT	Power Fail Transfer
PIM-SM	Protocol Independent Multicast-Sparse Mode
PoE	Power over Ethernet
POP3	Post Office Protocol 3
PPP	Point to Point Protocol
PPPoE	PPP over Ethernet
PPS	Pulse Per Second
PPTP	Point to Point Tunneling Protocol
PRI	Primary Rate Interface
PRS	Polarity Reverse Signal
PSTN	Public Switched Telephone Network
PSU	Power Supply Unit

Q

QAM	Quadrature Amplitude Modulation
QoS	Quality of Service

R

RF	Radio Frequency
RCM	R2 Caller identification Module
RTP	Real-time Transmission Protocol
RTPT	Real-time Transmission Protocol Transfer
RTPR	Real-time Transmission Protocol Receiver

S

SIP	Session Initiation Protocol
SLI	Single Line Interface
SLM	SLI Module
SMDR	Station Message Detail Recording
SME	Small Medium Enterprise
STP	Signaling Transfer Point
SMTP	Simple Mail Transfer Protocol
SONET	Synchronous Optical Network
SWM	Ethernet Switch Module

T

TAPI	Telephony Application Programming Interface
TEPRI	T1 E1 Primary Rate Interface
ToS	Type of Service
TRK	Trunk
TRM	TRK Module
TTS	Text-To Speech

U

UA	User Agent
UART	Universal Asynchronous Receiver and Transmitter
UDP	User Datagram Protocol
UMS	Unified Messaging Service
UNI	Universal
USB	Universal Serial Bus
UTP	Unshielded Twisted Pair

V

VDSL	Very high bit rate Digital Subscriber Line
VLAN	Virtual Local Area Network
VM	Voice Mail
VMS	Voice Mailing System
VoIP	Voice over Internet Protocol
VPM	Voice Processing Module
VPN	Virtual Private Network

W

WAN	Wide Area Network
WBS	Wireless Base Station
WIM	WAN Interface Module
WIP	Wireless IP Phone
WLAN	Wireless Local Area Network
WLI	Wireless LAN Interface



This page is intentionally left blank.

OfficeServ 7100 System Description

©2006 Samsung Electronics Co., Ltd.

All rights reserved.

Information in this manual is proprietary to SAMSUNG
Electronics Co., Ltd.

No information contained here may be copied, translated,
transcribed or duplicated by any form without the prior written
consent of SAMSUNG.

Information in this manual is subject to change without notice.

